



ADVANCED SOLUTIONS FOR FROZEN BEVERAGES
SINCE 1961



milkshake



cold drink



smoothie



frozen cocktail



granita



PROPANE GAS R290
BRUSHLESS FUN MOTOR
REMOVABLE AIR FILTER
SELF CLEANING
CONDENSER

Exclusive Features

Double augers for Better mix

Total cold system

"Seal-Less" drive shaft system which eliminates mandatory preventive maintenance

Electronic system, density control and auto diagnostic

Equipped with automatic cleaning and sanitizing valves

Exclusive customization with Led Backlit light panel

Elmeco First Class is available in two different color and it is possible to customize with your logo, graphics or advertising messages.

The addition of the **LED backlight panel** allows for complete customisation and a fresher, more appealing look.



Refill system. Maximize your output production

Elmeco Refill is a handy bag-in-box auto-fill system, easy to set up on the existing machines (FC2 and FC3). This additional equipment maximizes output production by keeping machine bowls full at all times and reinforces merchandizing effect. Eliminates potential human errors in process of premixing water and syrup.

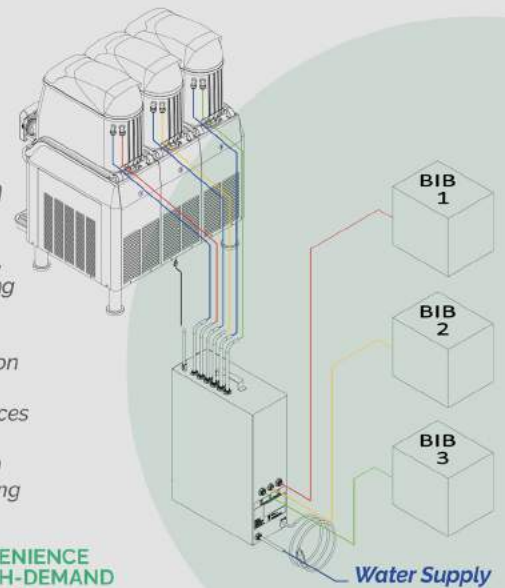

 IDEAL FOR CONVENIENCE STORES AND HIGH-DEMAND BEVERAGE SERVICE



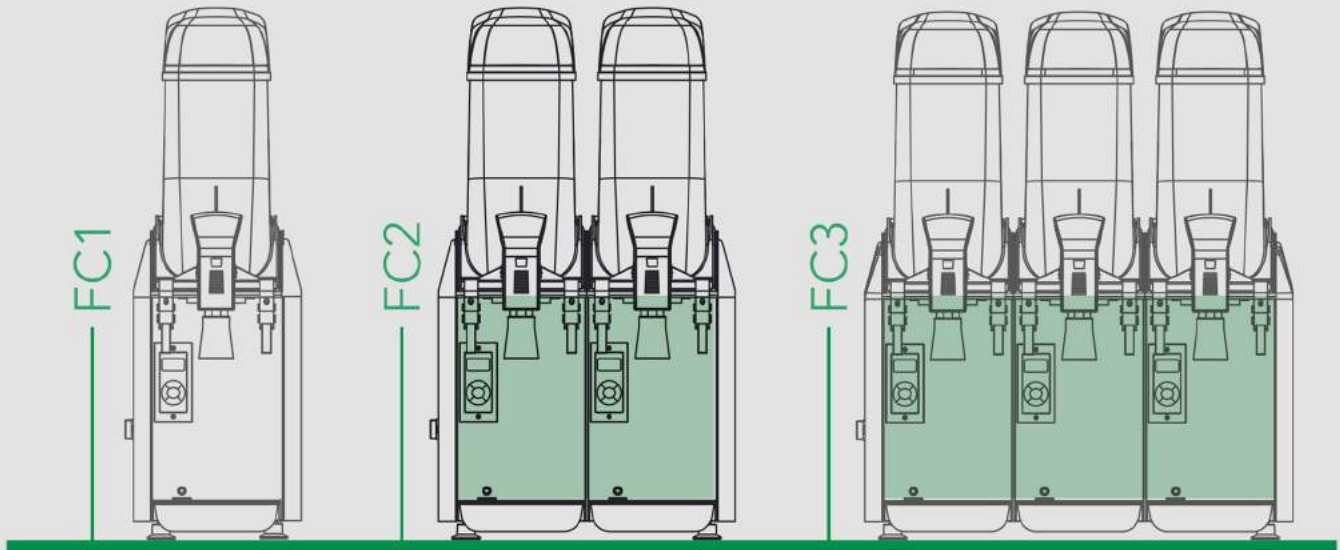

○ ● COLOURS AVAILABLE

■ FRONT LED BACKLIT LIGHT PANEL AVAILABLE

	DIMENSION			WEIGHT		CAPACITY		POWER		VOLTAGE
	H	W	D	KG.	LB.	LT.	GAL.	W	HP	V/HZ
FC1	771 mm 30.35 inc	240 mm 9.45 in	566 mm 22.28 in	31	68.30	12	3.17	500	0.67	220/240/50 220/60 115/60
FC2	771 mm 30.35 inc	430 mm 16.93 in	548 mm 21.57 in	52	114.60	24	6.34	930	1.24	220/240/50 220/60 115/60
FC3	771 mm 30.35 inc	620 mm 24.4 in	548 mm 21.57 in	64	141.10	36	9.51	1150	1.54	220/240/50 220/60 115/60

Keep your First Class tanks full at all times

AUTO-FILL SYSTEM BENEFITS

Bag-n-box (BIB) auto fill system product at rate of 2-3 oz per sec. (varies for different types of concentrate);

Power cord included, must be plugged in individually from the machine (110V/60Hz);

Equipped with automatic cleaning and sanitizing valves;

Contains pumps, tubes and solenoids in one, easy to handle box;

Equipped with automatic alarm when syrup BIB empty or insufficient water pressure provided;

Equipped with shurflo brix pumps at 3:1, 4:1 or 5:1.

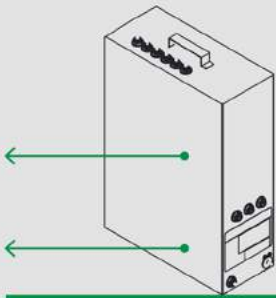

5 years on compressor parts (USA / Canada only)
3 years on electronic parts (USA / Canada only)
2 years on functional parts
1 years on labor

