

# XVL 1 - XVL 3

Steel



---

# CARPIGIANI **SOFT SERVE CONSULTING**

---

**CARPIGIANI SOFT SERVE CONSULTING** consultants can help you transform your idea into a successful business!



Efficient  
Fundamental  
High performance

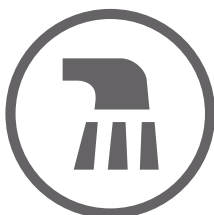



## PERFORMANCE AND QUALITY

Produce Soft Serve Gelato, Ice Creams, Sorbets and Frozen Yogurt. Thanks to the independent cylinders, in the XVL 3 it is possible to simultaneously mix products of different consistencies.



### Creamy Soft Serve Gelato

Thanks to the H-O-T system and to the type of feed (gravity or pump) it is possible to set the desired consistency for creamy ice creams, from a delicate Vanilla to a robust chocolate.



### Soft Serve Sorbets

Choose the desired consistency of the Serve Sorbets to create robust flavors with lots of fiber or classic lemon sorbet. Thanks to the H-O-T system and to the type of feed system used (gravity or pump).



### Frozen Yogurt

Choose the desired consistency of the Frozen Yogurt, to produce a classic frozen yogurt or a unique soft serve gelato yogurt. Thanks to the H-O-T system and to the type of feed system used (gravity or pump).



### Custom shape Gelato

Legend: Optional ONLY upon purchase Optional available even after purchase



# PERFORMANCE AND QUALITY

## Star Door

Star Door allows the use of the new nozzles and the single-portion kit.



## Optional Monoportion kit.

Kit of nozzles suitable for filling small cups, cannoli's and other frozen dessert monoportions.



**Optional Blender.** Integrated blender uses disposable spoons to conveniently and hygienically mix toppings or syrups into a soft serve cup.



**Optional Nozzles.** Customize the Soft Serve by choosing new and unique nozzles that fit your style.



**Gravità - Gravity**

**Pompa - Pump**

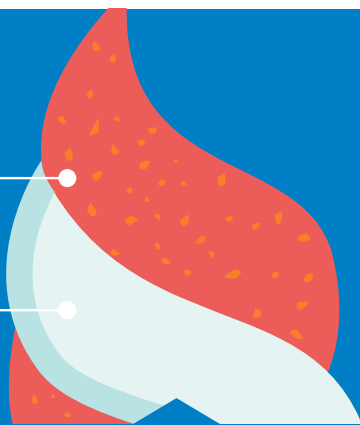

**Optional Pump / Gravity kit (Only for XVL 3 P models using the POM Beater)** Run pump & gravity feed cylinders at the same time. Simultaneously serve traditional mixes and mixes with lots of fiber or fruit seeds.



## Optional Winter Door (for XVL 3 models).

This unique door is composed of two separate doors. Giving the user the freedom to operate one or both cylinders or even operate one cylinder while cleaning the other. The twist door is inhibited.





## PERFORMANCE AND QUALITY

**Hard-O-Tronic®.** The electronic control system that allows you to change the consistency of the Soft Serve in a simple and fast way.

### Choice of **MIX FEEDING SYSTEM**

#### **Submerged Pump - Version P**

Ideal for creating dry and compact Soft Serve. Pressurized steel pump with advanced thermoplastic polymer gears. Thanks to the holes in the pump regulator, it is possible to obtain 40-80% overrun. It is possible to adjust the overrun even when the tank is full!

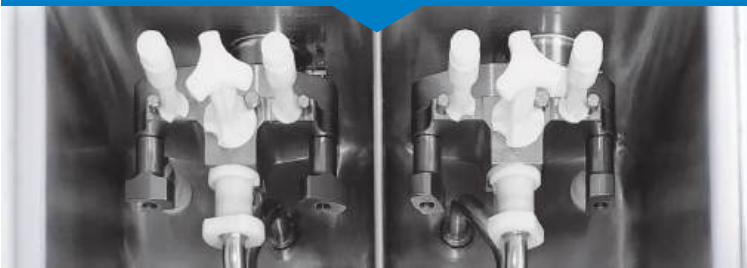

#### **Gravity - Version G**

Ideal for a dry and compact Soft Serve able to contain a high amount of fibers or small fruit pieces with an overrun of up to 40%. The different diameters of the holes on the feeding needle naturally dose the mixture with air. Thanks to the repeated holes both on the lower part and on the upper part of the overrun adjuster, it is possible to adjust the overrun even when the tank is full!



### **BEATER** Choice

#### **2E-RSI High Efficiency Beater**

Ideal for soft and Creamy Soft Serve. Stainless steel beater with plastic scrapers and removable shaft.



#### **High Efficiency Beater in POM**

Ideal for Frozen Yogurt, Yogurt mixes and Creamy Soft Serve with gravity fed recipes. Convenient Monobloc beater in food-grade plastic. Standard in gravity versions.



#### **Direct expansion cylinder**

Optimized refrigeration process. Faster freezing times & more energy savings. Pre-loading operation is simple and safe, thanks to the new position of the feed hole.



Legend:  Optional ONLY upon purchase  Optional available even after purchase



# CONVENIENCE

New solutions for maximum **convenience** during use

### Tank Agitator

Prevents product stratification during storage and improves heat exchange during pasteurization.



### Adjustable dispensing speed

Adjustable delivery flow to meet all volume and speed needs.



### Self Closing

User-friendly Self Closing levers automatically close to stop the flow of product, eliminating any waste. Automatic self closing levers are easy to assemble & disassemble. Ideal for rotating staffs.



### Pinless Aluminum levers

When the machine is not manned, the levers can be removed and reassembled quickly, without the use of tools.



### Optional Dry Filling system

Automatic dry filling system, allows users to automatically add water as well as mix powder mixtures directly in the tank, saving time, space and reducing the possibility of dosing errors.



Scan the **QR Code** on the front of the machine to access the most up to date equipment information: Instruction Manual, Carpi Care kit & Carpi Clean kit.

**Versatile machine (for XVL 3 models).** Thanks to three different functions, it is possible to choose the side on which you want to operate. Left side only or right side only in low season, both during high productivity.



## SAVINGS

New **high-performance** electric gearmotors and condensers

**Independent pump transmission.** (P version). Extends the life of the pump and gears. Ensures flexibility with high performance.



### Choice of **COOLING**



#### **Water Cooled machine**

Refrigeration system is cooled thanks to the inlet and outlet water circuit, conveniently located at the rear of the machine.



#### **Air cooled machine**

Thanks to the rear chimney, it is possible to optimize the installation space and to place the machines side by side.

**Minimum residue of mixture** in the tank (0.2 liters.) Thanks to the conformation with depression in the rear part of the tank, during the cleaning phase the waste of the mixture is minimal.



## SAFETY

**More operational safety** and **more control** during production



**Ergonomic design.** Reduced risk of injury, with corners even rounder where the operator works.

#### **Black-out and water outage**

After a power or water failure, if the temperature-time parameters guarantee that the mixture has not undergone any alteration, the machine resumes the program in progress. Otherwise, if the machine is self-pasteurizing, a pasteurization cycle is automatically started, warning the operator with a message on the display. In the case of the non self-pasteurizing version, the machine requires washing.



#### **Optional Teorema**

Guarantees facilitated assistance by providing on-line monitoring and diagnosis on a tablet, phone or PC wherever you are.



#### **Button lock**

For added security, the display buttons can be locked to prevent accidental errors.





# HYGIENE

Easy cleaning,  
**guaranteed hygiene**

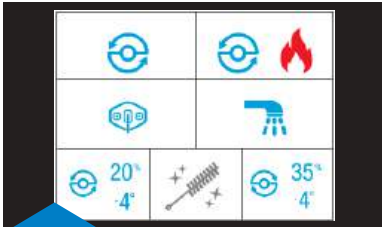

## Multifunctional Cleaning Button

Possibility to activate or deactivate the pump and the beater individually or together according to cleaning needs. One of the functions is hot cleaning. By simultaneously activating the beater and the heating of the cylinder surface, the production grease residues are quickly dissolved.

## Optional Wash kit

Water Tap is added over the tank to facilitate cleaning.

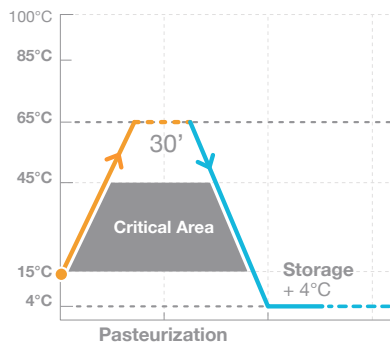

With the automatic **self-pasteurization** system you can choose when to wash the machine up to a maximum interval of 42 days. As a further guarantee of hygienic safety, if the operator does not perform the complete cleaning at the end of the set days, the machine goes into automatic block.



## Removable pump shaft

It simplifies cleaning procedures and guarantees maximum hygiene and reliability.

## Carpi Care kit



Custom kits, designed to always keep your machine hygienically perfect.



## Carpi Clean kit

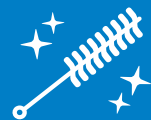

**Scheduled start.** Set the pasteurization, storage programs to automatically run at a convenient time for you, such as overnight and be fully functional the next day.

## Ergonomic lid

Ergonomic transparent tank lid for easy tank inspection.



# MACHINE CONFIGURATION

## TANK CONFIGURATION

### CHOOSE THE PRODUCT FEED SYSTEM

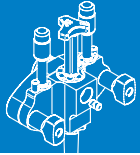

**Pump**

Optional



**Gravity**

Optional



**Wash kit**



**Dry filling system**

## BEATER & DOOR CONFIGURATION

### CHOOSE THE TYPE OF BEATER



**2E-RSI Beater**

Optional. Available for XVL 3

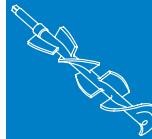

**POM Beater**

Optional

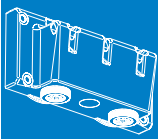

**Winter Door**

Optional



**Nozzles**



**Monoportion kit**

# MACHINE CONFIGURATION

## TECHNICAL CONFIGURATION

### CHOOSE THE TYPE OF CONDENSATION XVL 1 COUNTER

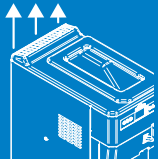

**Air Cooled machine**

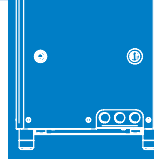

**Water Cooled machine**

### CHOOSE THE TYPE OF CONDENSATION XVL 1 XVL 3

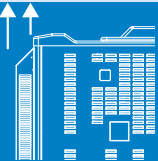

**Air Cooled machine**

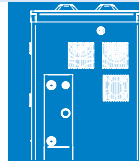

**Water Cooled machine**

Optional only for XVL 1 XVL 3  
Standard for XVL 1 Counter

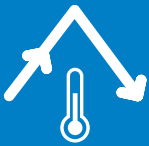

**Self-Pasteurization**

### CHOOSE THE TYPE OF POWER SUPPLY



**Power supply  
Single-phase / Three-phase**

## ACCESSORIES CONFIGURATION

Optional. Available for XVL3 P

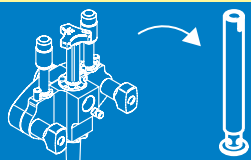

**Pump kit /  
Gravity kit**

Optional

**TEOREMA  
Teorema**

Optional



**Blender**

## WHO WE ARE

**Carpigiani Services.** Always by your side! The extensive Carpigiani service network is at your disposal with a widespread assistance network that guarantees a wide coverage of the territory with over 480 authorized service centers and 1500 specialized technicians around the world, for over 70 years guaranteeing a widespread, global presence. Carpigiani Services ensures rapid and professional assistance.

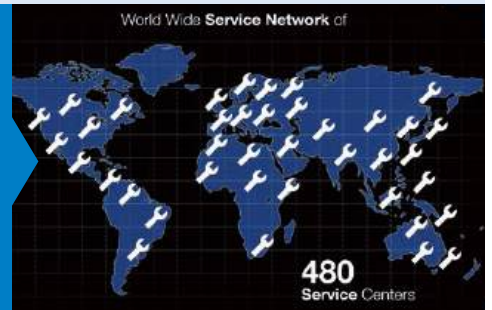

## WHAT WE OFFER

**Original spare parts.** Carpigiani original spare parts, manufactured in compliance with national and international food safety regulations, ensure the durability of the components and extend the life of the machine. They are the only ones able to guarantee efficiency and safety. Carpigiani original spare parts are guaranteed for 1 year.



### Carpi Care kit



6

MONTHS

Periodically ask your dealer **Carpi Care kit and Carpi Clean kit.** Dedicated kit of gaskets and brushes to keep each machine hygienic & clean.

### Carpi Clean kit

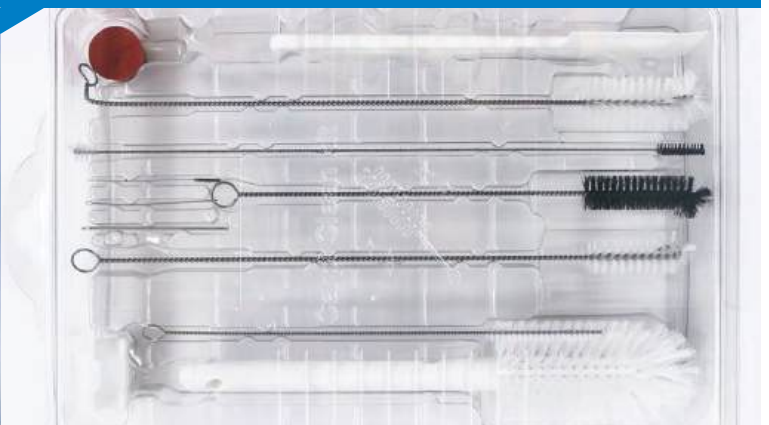
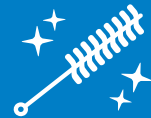

## WHAT WE OFFER

**Specialized technicians.** Carpigiani technicians are professionals who are always up-to-date thanks to solid and constant training courses that guarantee high levels of competence for any inspection, maintenance, cleaning and repair intervention.



**Preventive maintenance.** Thanks to periodic checks, entrusted to certified technicians, the machine can always work in optimal conditions, preventing any downtime.

**Extended Warranty.** Operate machine in complete tranquility, thanks to the Carpigiani extended warranty. In case of needs, in fact, Carpigiani technicians are able to restore machine operation with original spare parts.

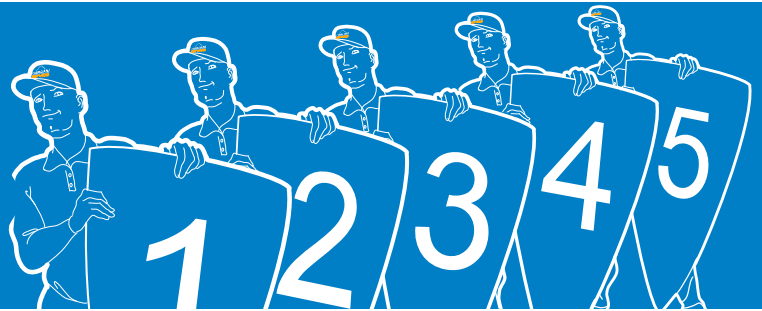

**Scheduled Cleaning.** Possibility of entrusting the periodic cleaning of the machine to expert technicians.



**Teorema.** Teorema Remote Control and diagnosis system for remote monitoring of machine operation. The customer can access the machine via computer, tablet or mobile device to remotely monitor operations. Teorema also facilitates the assistance service: Carpigiani technicians are alerted on the configuration parameters as if they were operating directly on the machine.



**technical data - dimensions**

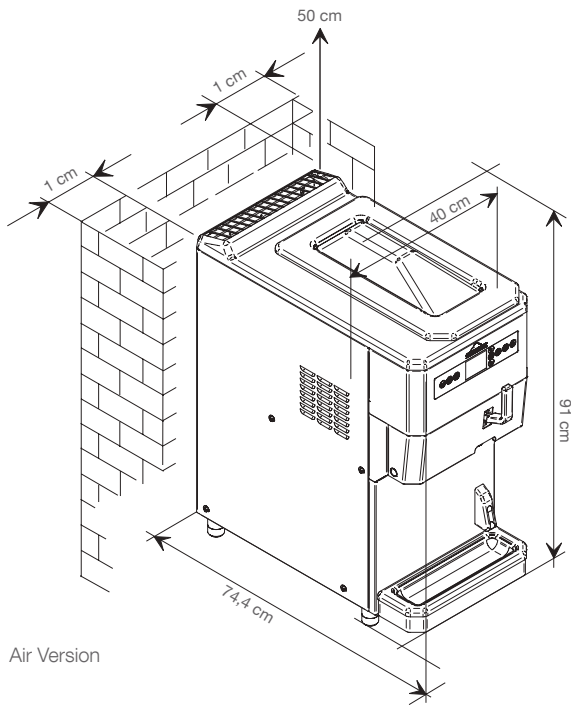

Air Version

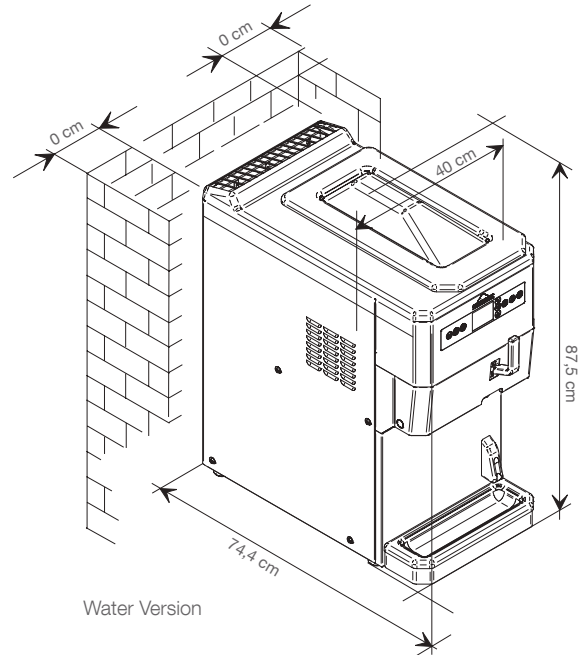

Water Version

**XVL 1 Counter**

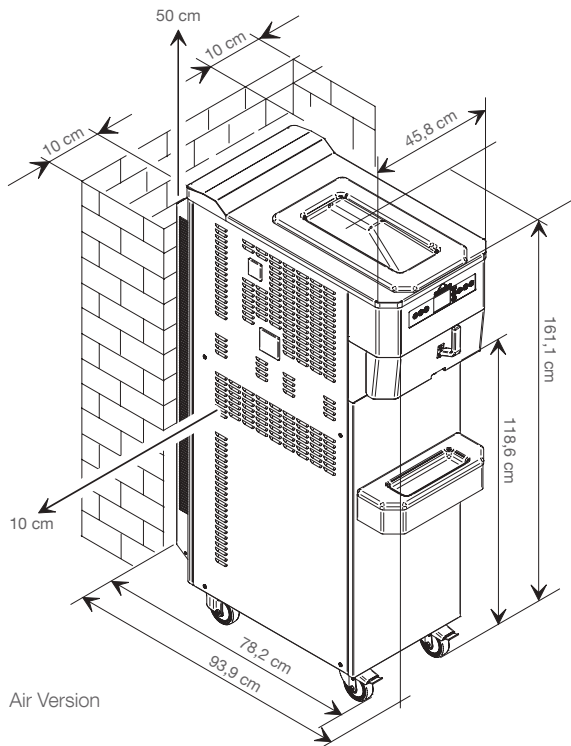

Air Version

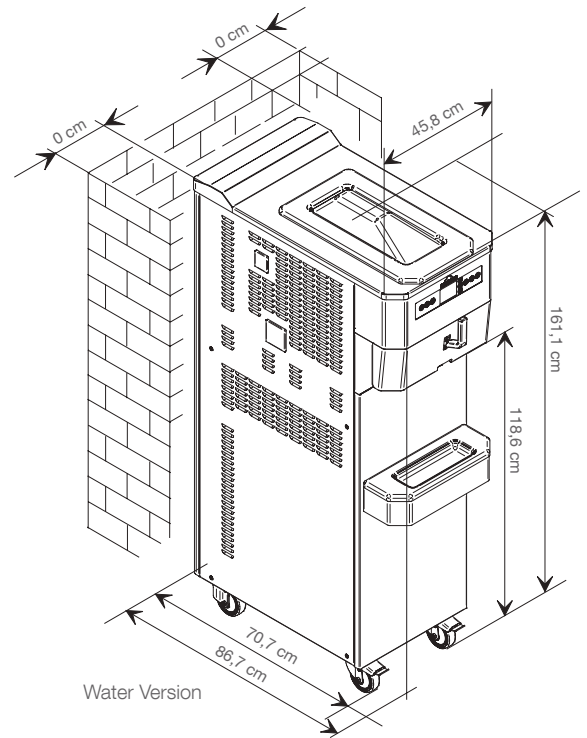

Water Version

**XVL 1 STEEL**

technical data - dimensions

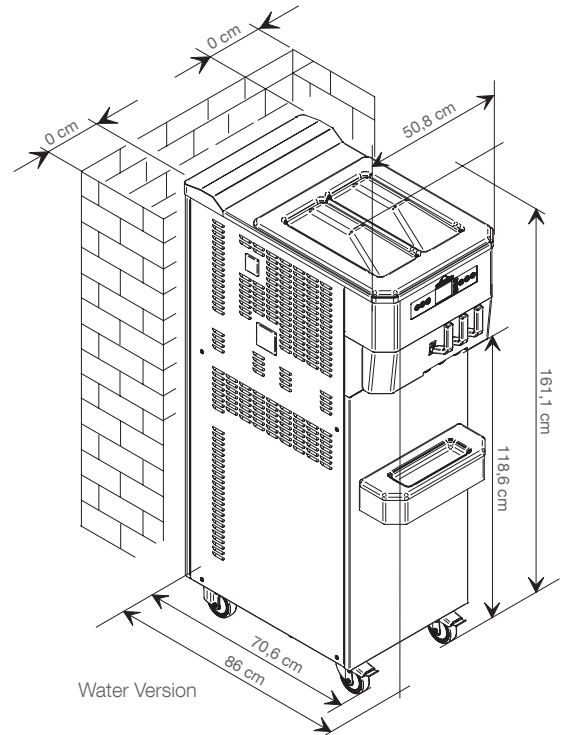
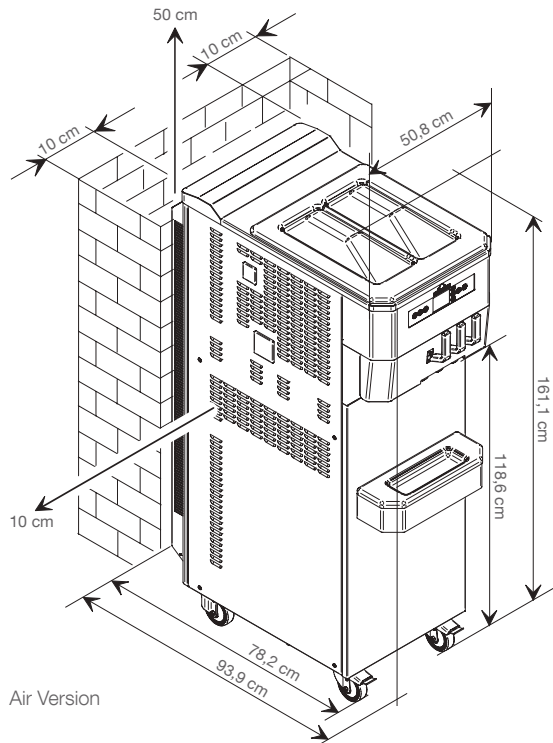

XVL 3 STEEL

# XVL 1 - XVL 3

## Steel



|                           | Flavours | Mix Delivery System | Mix Delivery System (75gr portions) |        | Tank Capacity<br>lt | Cylinder Capacity<br>lt | Rated Power Input<br>kW | Fuse Size<br>A | Power Supply<br>Volt Hz Ph | Cooling System      | Refrigerant | Net Weight<br>kg |
|---------------------------|----------|---------------------|-------------------------------------|--------|---------------------|-------------------------|-------------------------|----------------|----------------------------|---------------------|-------------|------------------|
|                           |          |                     | POM                                 | 2E-RSI |                     |                         |                         |                |                            |                     |             |                  |
| <b>XVL 1 Counter P SP</b> | 1        | Pump                | -                                   | 310*   | 13                  | 1,75                    | 2,4                     | 10             | 400/50/3**                 | Air, water optional | R452***     | 170              |
| <b>XVL 1 Counter G SP</b> |          | Gravity             | 265*                                | -      |                     |                         |                         |                |                            |                     |             | 160              |
| <b>XVL 1 Steel P</b>      | 1        | Pump                | 465*                                | 510*   | 13                  | 1,75                    | 2,5                     | 10             | 400/50/3**                 | Air, water optional | R452***     | 230              |
| <b>XVL 1 Steel G</b>      |          | Gravity             | 440*                                | -      |                     |                         | 2,4                     |                |                            |                     |             | 225              |
| <b>XVL 3 Steel P</b>      | 2+1      | Pump                | 630*                                | 695*   | 13+13               | 1,75                    | 5,0                     | 16             | 400/50/3**                 | Air, water optional | R452***     | 310              |
| <b>XVL 3 Steel G</b>      |          | Gravity             | 600*                                | -      |                     |                         | 4,8                     |                |                            |                     |             | 300              |

\*production capacity depends on the mix used and the room temperature \*\*other voltages and cycles available upon request  
 \*\*\*alternative solutions available.

XVL are produced by Carpigiani with UNI EN ISO 9001 Certified Quality System.

All specifications mentioned must be considered approximate; Carpigiani reserves the right to modify, without notice, all parts deemed necessary.



Via Emilia, 45 - 40011 Anzola dell'Emilia - BOLOGNA, Italy - T. +39 051 6505111 - info@carpigiani.it

an Ali Group Company



The Spirit of Excellence