



Features

Independent Control

The upper and lower heaters of each warming slot can be independently set and controlled for temperature.

Temperature Range

Each heater's temperature ranges from 65°C to 127°C.

Temperature Setting Protection

The controller does not display the current set temperature. A specific function can be programmed to prevent changes to the temperature setting.

Dual-Sided Operation

Dual-sided design allows convenient placement and retrieval of food from both the front and rear sides.

Fried and Non-Fried Foods

Each layer can keep both fried and non-fried foods warm by using different trays.

Tray Cover Design

Unique drawer-style tray cover allows it be easily pulled-out. Drawers can be fastened in fixed positions to prevent food from falling off the cabinet.

Technical Specifications

Product Category	Dedicated Holding Bins
Model Number	DH-S22
Product Dimension	W460mm x D520mm x H245mm
Electric Parameter	208-240V, 50/60Hz
Power	1145-1525W, 5.5-6.4A
Use Design	Double-faced
Capacity	1/1GN Number of disks 2pcs
Heater	Rope Heater
Exterior Structure	Stainless Steel
Interior Structure	Stainless Steel and Aluminum
Net Weight	20.8Kg
Shipping Weight	28Kg
Shipping Size	L690mm x W580mm x H390mm
Warranty	One year
Agency Listing	GB

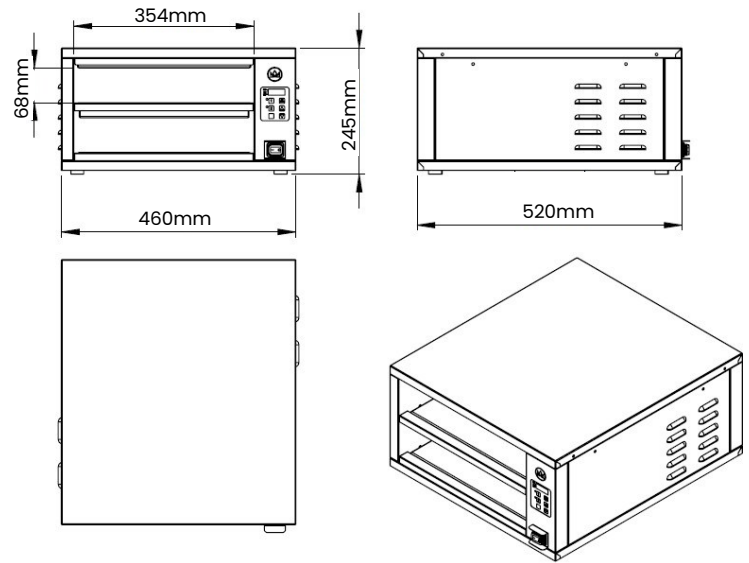

For details about the materials required for installation, please refer to the Installation Manual.