

Magica E-PAY

Self-service



241 Magica
E-PAY
counter top
SP P



241 Magica
E-PAY
SP P



241 Magica
E-PAY
Colore
SP P



CARPIGANI **SOFT SERVE & SHAKE CONSULTING**

CARPIGANI SOFT SERVE & SHAKE CONSULTING consultants transform your idea into a successful business!



**Machine
Configuration
& Settings**

**Food
Style**

**Mix & Recipe
Development**

**Operations
Management**

Self-service
single flavor
counter-top and
floor-standing
machines with
**contactless
payment
technology**

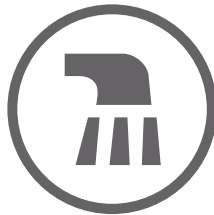



PERFORMANCE AND QUALITY

Magica!

E-PAY Self-service

The technology that allows you to dispense predetermined portions of soft serve with the push of a button.



Creamy Soft Serve Gelato

Thanks to the H-O-T system and the product feed system it is possible to set the desired consistency for creamy Soft Serve, from a delicate vanilla up to a strong chocolate.



Soft Serve Sorbets

Choose the desired consistency of the Soft Serve Sorbets, thanks to the H-O-T system and the product feed system.



Frozen Yogurt

Choose the desired consistency of the Frozen Yogurt, to produce a classic frozen yogurt or a unique soft serve gelato yogurt. Thanks to the H-O-T system.



Variegated Gelato

Thanks to the pressurized syrup system it is possible to automatically variegate the gelato, creating homogeneous lines of syrup only on the crests, thus having three different proposals.

Legend:  ONLY Optional upon purchase  Optional available even after purchase



PERFORMANCE AND QUALITY



1) choose your gelato

Only for the Magica E-PAY Colore version you can choose between 3 options: single flavor ice cream & two ice creams with flavored syrup on the crests



2) choose your size: small or large



3) pay using the contactless device



4) once payment has been confirmed, position the cup and press "OK".

The ice cream is ready!

Legend: ONLY Optional upon purchase Optional available even after purchase



PERFORMANCE AND QUALITY

Hard-O-Tronic®. The electronic control system gives you the power to quickly choose the consistency of the Soft Serve in a simple manner and change it for a variety of styles of your choosing.

MIX FEEDING SYSTEM



Pump - Version P

Ideal for creating dry and compact Soft Serve. Pressurized steel pump with advanced thermoplastic polymer gears. Thanks to the holes in the pump regulator, it is possible to obtain 40-80% overrun. It is possible to adjust the overrun even when the tank is full!

BEATER



2E-RSI High Efficiency Beater

Ideal for soft and Creamy Soft Serve. Stainless steel beater with plastic scrapers and removable shaft.



1.75 L Direct expansion cylinder

Optimized refrigeration process. Faster freezing times & more energy savings. Pre-loading operation is simple and safe, thanks to the new position of the feed hole.

Legend:  ONLY Optional upon purchase  Optional available even after purchase



CONVENIENCE

New solutions for maximum **convenience during use**



Tank Agitator

Prevents product stratification during storage and improves heat exchange during pasteurization.



Portions

Possibility to set two different portion sizes, small or large, and to set a different price for each size.



10" touch screen display

Guides the customer step-by-step in dispensing their soft serve.

It allows you to customize the background colour and product name, choose between cone or cup, set the price based on the selected portion, and more.



Contactless technology

It makes the machine fully self-service to enable portion dispensing only upon **contactless payment** via credit card, smartwatch, or digital wallet.

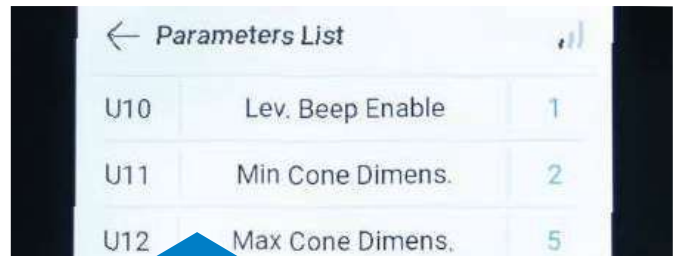

Quick selection parameters for making small variations in the size of ice cream to be dispensed.



CONVENIENCE

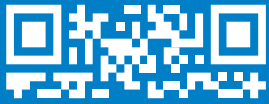

QR CODE

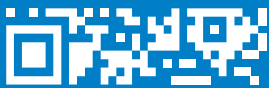

Scan the **QR Code** on the front of the machine to access the most up to date equipment information: Instruction Manual, Carpi Care kit & Carpi Clean kit.



Drip tray avoids overflowing from washing or spillage during production. Increasingly helpful for high production self-service machine.

Cup holder Arm, completely removable for complete cleaning thanks to the "bayonet" attachment.



Standard Cup holder with base diameter of 62 mm. As an **Optional**, certain shapes and sizes can be customized upon request.

Pressurized system (only for Magica E-PAY Colore models) for dispensing syrups, the machine feeds two containers in the lower part for specific syrups with the desired flavor. The third container is supplied for the daily washing of the syrup lines.



Legend: ONLY Optional upon purchase Optional available even after purchase



SAVINGS

New **high-performance** electric gearmotors and condensers

Choice of **COOLING**

Water Cooled machine

Refrigeration system is cooled thanks to the inlet and outlet water circuit, conveniently located at the rear of the machine.



Air Cooled machine

Thanks to the rear chimney, it is possible to optimize the installation space and to place the machines side by side.



Independent pump transmission

Extends the life of the pump and gears. Ensures flexibility with high performance.



Legend:  ONLY Optional upon purchase  Optional available even after purchase



SAFETY

More operational safety and **more control** during production



Ergonomic design

Reduced risk of injury, with corners even rounder where the operator works.



Column light to warn the operator if the machine has alarms or if the mixture is running out.

Black-out and water outage

After a power or water failure, if the temperature-time parameters guarantee that the mixture has not undergone any alteration, the machine resumes the program in progress. Otherwise, if the machine is self-pasteurizing, a pasteurization cycle is automatically started, warning the operator with a message on the display. In the case of the non self-pasteurizing version, the machine requires washing.



Teorema

Guarantees facilitated assistance by providing on-line monitoring and diagnosis on a tablet, phone or PC wherever you are.



Legend:  ONLY Optional upon purchase  Optional available even after purchase



HYGIENE

Scheduled start. Set the production, pasteurization, and storage programs to automatically run at a convenient time for you, such as overnight, to be fully operational the next day.

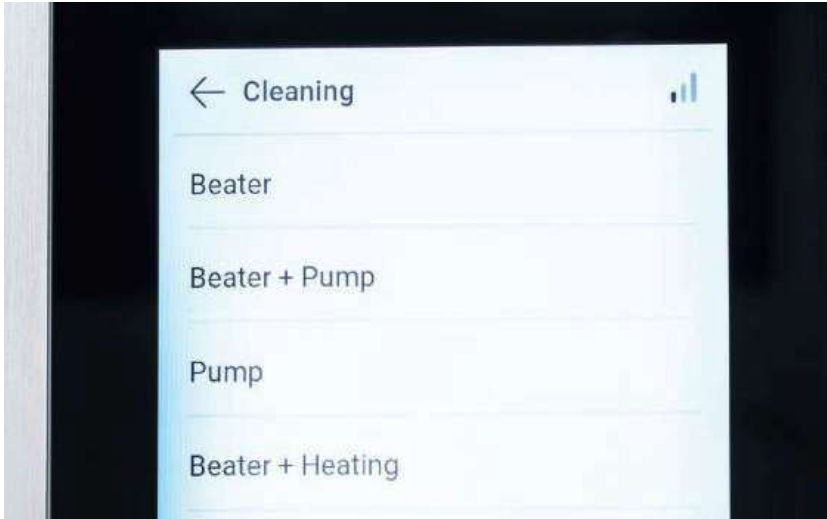

Menu: Multifunctional Cleaning. Possibility to activate or deactivate the pump and the beater individually or together according to cleaning needs. One of the functions is hot cleaning. By simultaneously activating the stirrer and the heating of the cylinder surface, the production grease residues are quickly dissolved.



Secure dispensing. Once the cup approaches the ice cream dispensing door, the extraction always takes place in a protected area thanks to the shaped protection plexiglass. For thorough cleaning, the protection can be removed.



Wash kit

Water Tap is added over the tank to facilitate cleaning.



Carpi Care kit



Custom kits, designed to always keep your machine hygienically perfect.

CARPIGIANI
services

Carpi Clean kit



Legend: ONLY Optional upon purchase Optional available even after purchase



HYGIENE

Easy cleaning,
guaranteed hygiene

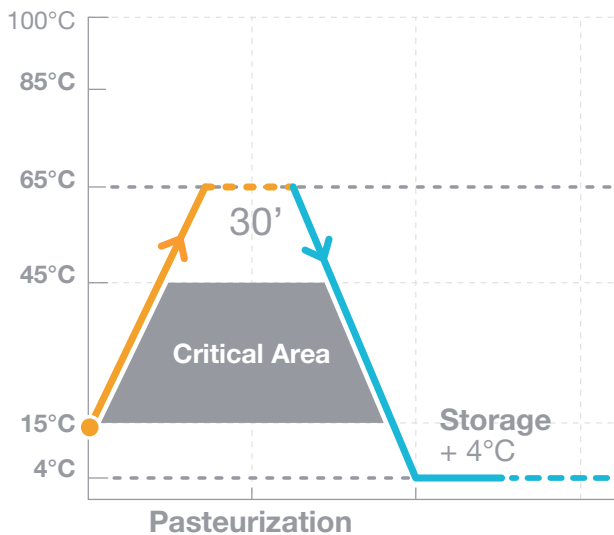

Standard. With the automatic **self-pasteurization** system you can choose when to wash the machine up to a maximum interval of 42 days. As a further guarantee of hygienic safety, if the operator does not perform the complete cleaning at the end of the set days, the machine goes into automatic block.



Removable pump shaft

Simplifies cleaning procedures, guaranteeing maximum hygiene and reliability.

Ergonomic plastic tank lid with key lock. Ensure the hygienic safety of the machine by preventing accidental opening by the public.



Legend: ONLY Optional upon purchase Optional available even after purchase

MACHINE CONFIGURATION

SALES CONFIGURATION

CHOOSE THE VERSION



Standard version



Color version
(only for 241 Magica E-PAY
Colore models)

CHOOSE TYPE AND SIZE



Cup



Cone

CHOOSE PORTION QUANTITY



adjustable portion
from 65 gr to 120 gr

TANK CONFIGURATION

CHOOSE THE PRODUCT FEED SYSTEM



Pump

Optional



Wash kit

BEATER & DOOR CONFIGURATION

TYPE OF BEATER



2E-RSI Beater

Legend:  ONLY Optional upon purchase  Optional available even after purchase

MACHINE CONFIGURATION

TECHNICAL CONFIGURATION

CHOOSE THE TYPE OF CONDENSATION

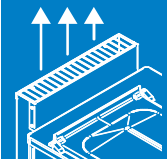

Air Cooled machine

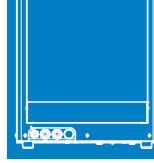

Water Cooled machine

CHOOSE THE TYPE OF POWER SUPPLY



**Power supply
Single-phase / Three-phase**

ACCESSORIES CONFIGURATION

Optional



Teorema

WHO WE ARE

Carpigiani Services. Always by your side! The extensive Carpigiani service network is at your disposal with a widespread assistance network that guarantees a wide coverage of the territory with over 500 authorized service centers and 1500 specialized technicians around the world, for over 70 years guaranteeing a widespread, global presence. Carpigiani Services ensures rapid and professional assistance.



WHAT WE OFFER

Original spare parts. Carpigiani original spare parts, manufactured in compliance with national and international food safety regulations, ensure the durability of the components and extend the life of the machine. They are the only ones able to guarantee efficiency and safety. Carpigiani original spare parts are guaranteed for 1 year.



Carpi Care kit



6 MONTHS

Periodically ask your dealer **Carpi Care kit and Carpi Clean kit.** Dedicated kit of gaskets and brushes to keep each machine hygienic & clean.

Carpi Clean kit



WHAT WE OFFER

Specialized technicians. Carpigiani technicians are professionals who are always up-to-date thanks to solid and constant training courses that guarantee high levels of competence for any inspection, maintenance, cleaning and repair intervention.



Preventive maintenance. Thanks to periodic checks, entrusted to certified technicians, the machine can always work in optimal conditions, preventing any downtime.

Extended Warranty. Operate machine in complete tranquility, thanks to the Carpigiani extended warranty. In case of needs, in fact, Carpigiani technicians are able to restore machine operation with original spare parts.



Scheduled Cleaning. Possibility of entrusting the periodic cleaning of the machine to expert technicians.



Teorema. Teorema Remote Control and diagnosis system for remote monitoring of machine operation.

The customer can access the machine via computer, tablet or mobile device to remotely monitor operations. Teorema also facilitates the assistance service: Carpigiani technicians are alerted on the configuration parameters as if they were operating directly on the machine.



Technical Data - Dimensions

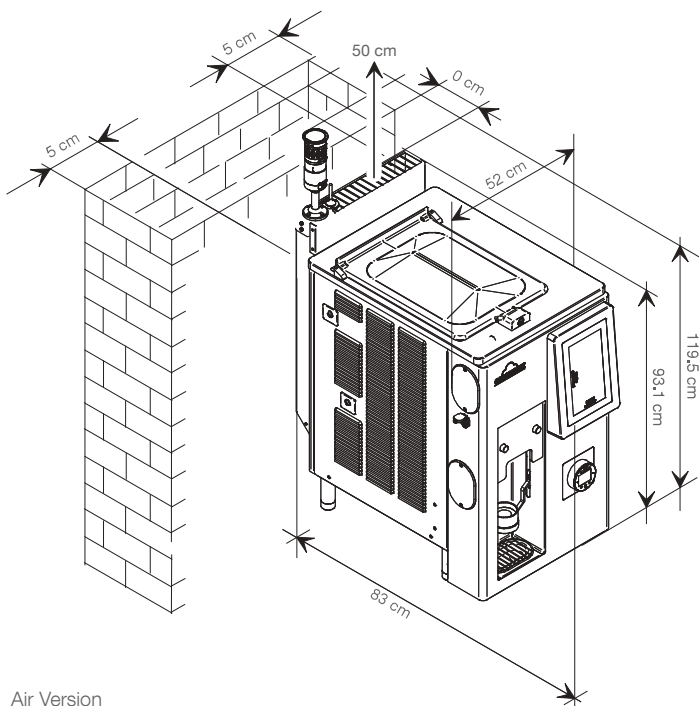

Air Version

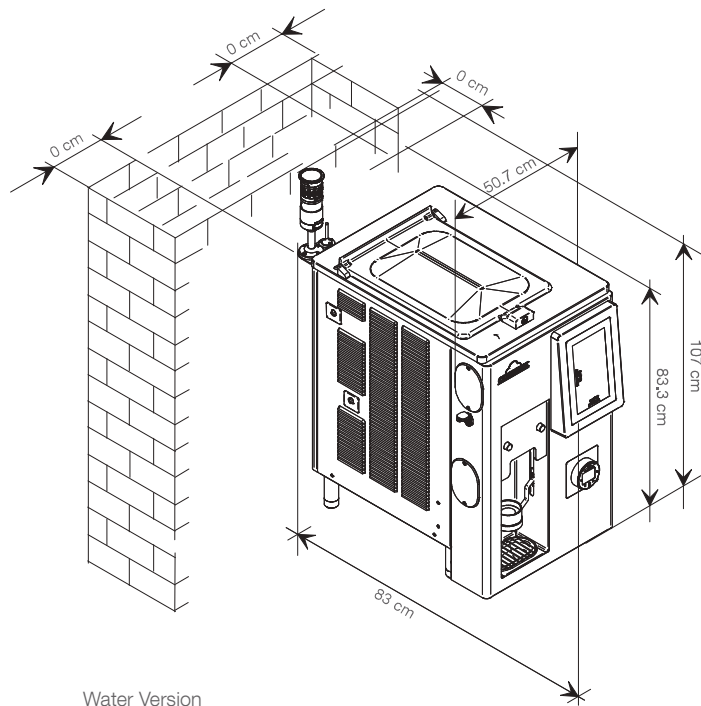

Water Version

241 Magica E-PAY counter top SP P

Technical Data - Dimensions

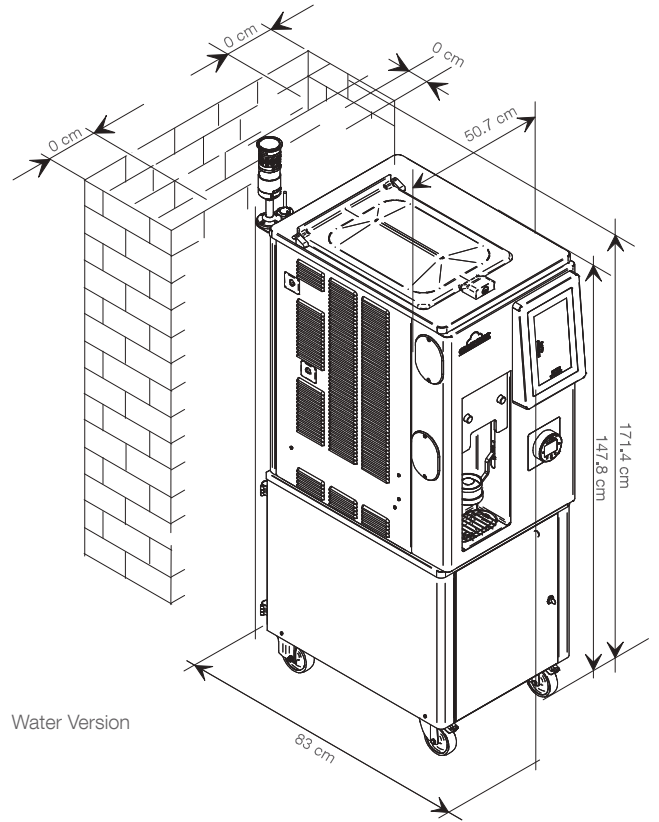
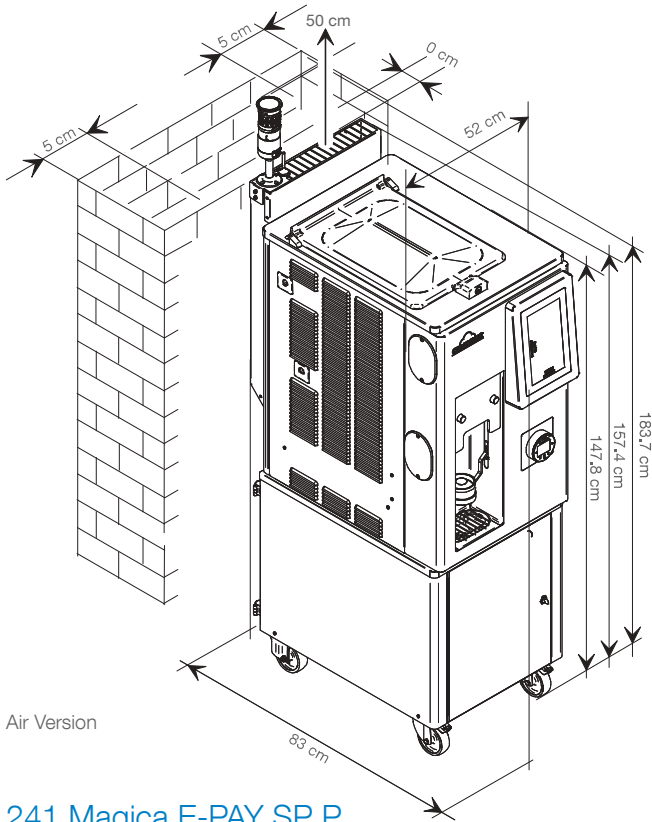

241 Magica E-PAY SP P

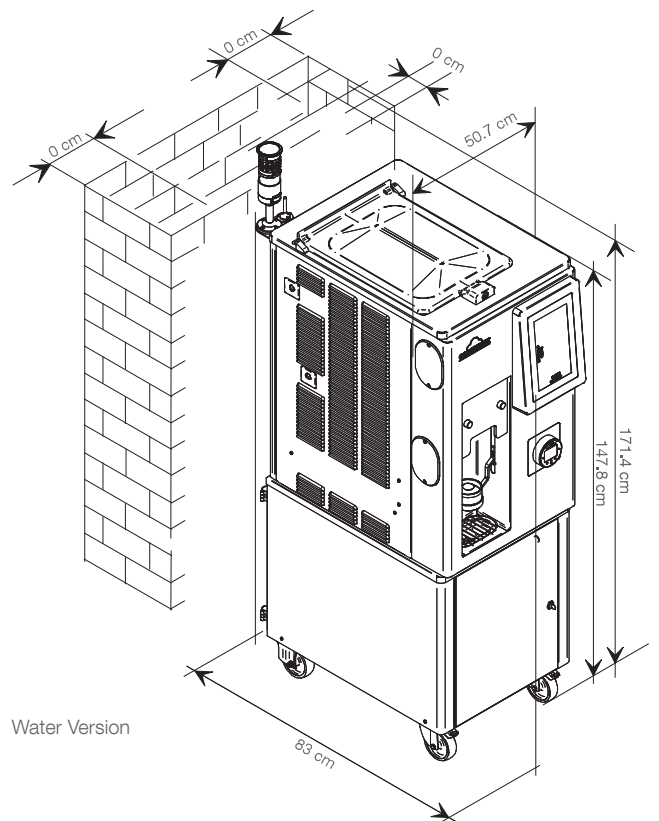
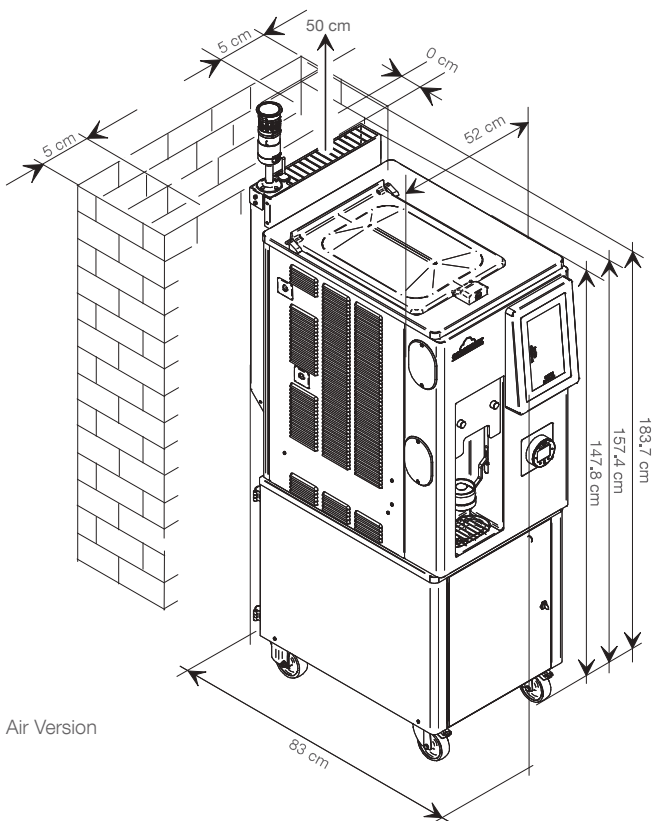

241 Magica E-PAY Colore SP P

Magica E-PAY

Self-service



	Flavours	Mix Delivery System	Hourly production <i>(75gr portions)</i>	Tank Capacity <i>lt</i>	Cylinder Capacity <i>lt</i>	Rated Power Input <i>kW</i>	Fuse Size <i>A</i>	Power Supply <i>Volt Hz Ph</i>	Cooling System	Refrigerant	Net Weight <i>kg</i>
 241 Magica E-PAY counter top SP P	1	Pump	320*	12	1.75	2.9	10	400/50/3**	Air, water optional	R455A or R454C	146
241 Magica E-PAY SP P	1	Pump	320*	12	1.75	2.9	10	400/50/3**	Air, water optional	R455A or R454C	223
241 Magica E-PAY Colore SP P	1+2 variegates	Pump	320*	12	1.75	2.9	10	400/50/3**	Air, water optional	R455A or R454C	235

*production capacity depends on the mix used and the room temperature **other voltages and cycles available upon request.

Magica E-PAY Self-service are produced by Carpigiani with Quality System UNI EN ISO 9001.

All specifications mentioned must be considered approximate; Carpigiani reserves the right to modify, without notice, all parts deemed necessary.