



BB20 Rollout

Capacity

Kg

100	+90°C +3°C ↓
78	+90°C -18°C ↓

Trolleys

1 Trolley GN1/1 or EN60/40

Functions

Shock Freezing

Blast chilling

Ice cream hardening

Fish sanitation

Pastry

Thawing

Pre-cooling

Hot gas defrosting

Bottle cooling

Cell sanitizing

Cell drying

CONSTRUCTION FEATURES

7" touch screen controller

Unibody AISI 304 stainless steel

Rounded internal corners

CFC free highdensity polyurethane insulation

Evaporator with cataphoresis protection against rust

Door hinge on left side

Heated door perimeter

External condensate drain tube

Front-access electrical box

Lock closure

CYCLES AND SOFTWARE

Probe cycles

Time cycles

Singleprobe cascade cycles

Timer cycles

Quick start

Customizable parameters

Multiple and customizable cycle stages

Adjustable fan speed

Cookbook

HACCP data collection

STANDARD EQUIPMENT

Heated core probe

Ethernet port

Wi-Fi connection

Machine on feet

Elec. exp. valve w/ driver (CO2 only)

OPTIONALS

Right hinged door

Bumpers

Ozone generator

Wooden cage packaging

Wooden crate packaging

TECHNICAL DATA

	PlugIn Air	Remote	H2O PlugIn	CO2 provision
Temperature range [°C]			-40/+40	
Cooling capacity (evap. -10°C / cond. 45°C) [W]	7233	-	7233	-
Required cooling capacity [W]	-	7233	-	7233
ø liquid line ["] [mm]	-	3/8" [10]	-	3/8" [10]
ø suction line ["] [mm]	-	7/8" [22]	-	5/8" [16]
Condensation	Air cooled	Remote	Water cooled	Remote
Refrigerant gas	R290	R404A/R452A	R290	CO2
GWP	3	3922	3	1
Climatic class	5	5	5	5
Power supply [V/ph/Hz]	380-420/3N/50	220-240/1N/50	380-420/3N/50	220-240/1N/50
Max absorption cold cycles [W/A]	4629/11,35	483/4,65	4377/11,35	483/4,65
Max absorption hot cycles [W/A]	1820/11,15	1820/11,15	1820/11,15	1820/11,15
Blast chilling capacity (+90°C/+3°C) [kg]	100	-	100	-
Freezing capacity (+90°C/-18°C) [kg]	78	-	78	-
Inside dimensions WxDxH [mm]	690x833x1545	690x833x1545	690x833x1545	690x833x1545
External dimensions WxDxH [mm]	1210x1081x2280	1210x1081x2124	1210x1081x2280	1210x1081x2124
Internal capacity [L]	888	888	888	888
Packing volume [m3]	3,5	3,5	3,5	3,5
Gross weight [kg]	410	350	410	350
Net weight [kg]	380	320	380	320
Gas charge [g]	3x150	-	3x105	-
Packaging dimensions WxDxH [mm]	1100x1240x2540	1100x1240x2540	1100x1240x2540	1100x1240x2540
Packaging dimensions of the second package WxDxH [mm]	-	-	-	-

EN22042

65°C / +10°C	kWh/Kg	-	65°C / -18°C	kWh/Kg	-
	min	-		min	-
	Kg	-		Kg	-

AIR-PLUG IN

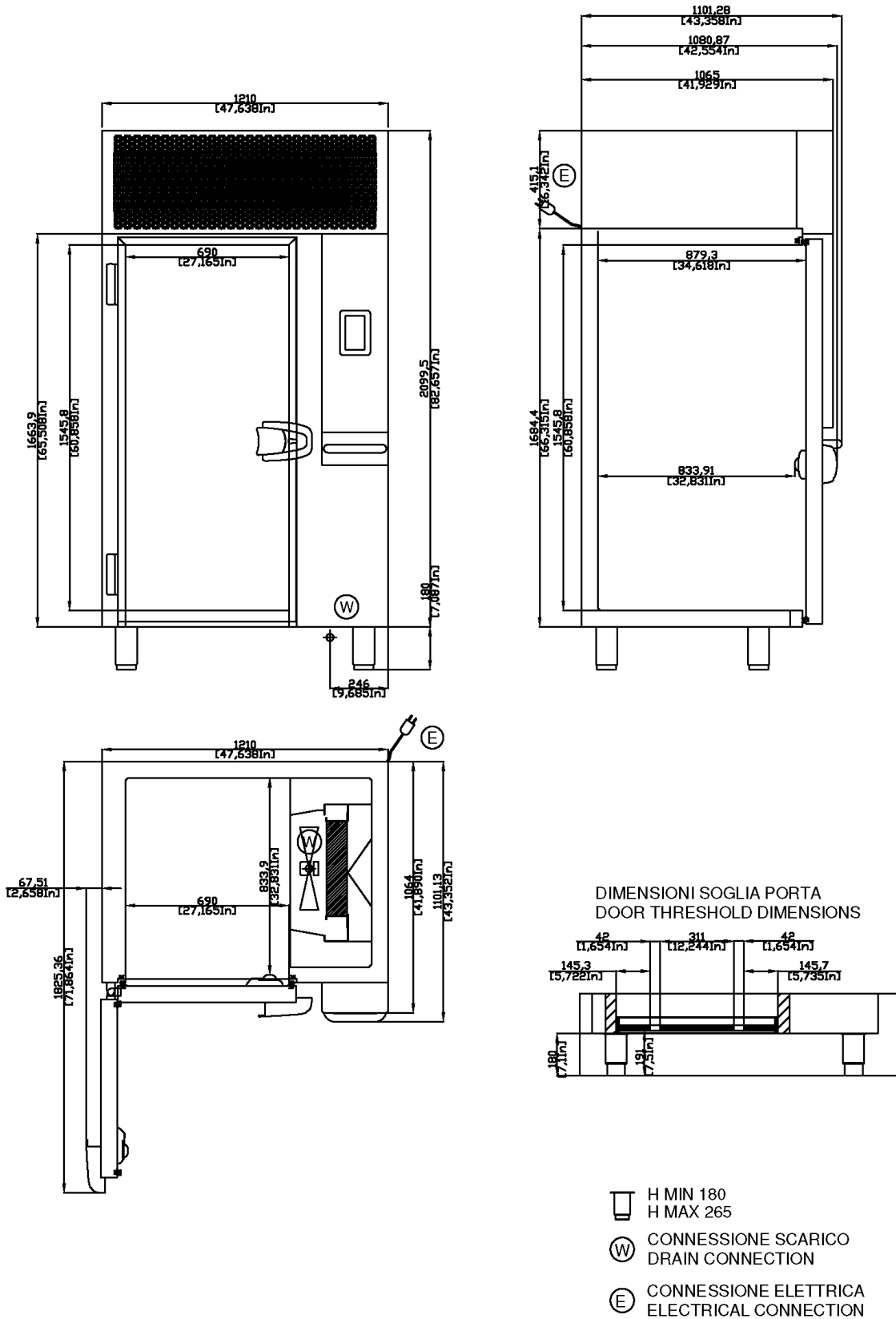

REMOTE

