



PLUS 15

Capacity

Kg

68	+90°C +3°C ↓
52	+90°C -18°C ↓

Trays

78	Trays pitch [mm]
15	GN 1/1 (H40 - 65)
30	GN 1/1 (H20)
30	EN 60/40

Functions

Shock Freezing	Blast chilling	Ice cream hardening	Fish sanitation	Pastry
Thawing	Low temp cooking	Retherm	Proofing	Bottle cooling
Pre-cooling	Pre-heating	Cell sanitizing	Cell drying	Hot gas defrosting

CONSTRUCTION FEATURES

7" touch screen controller
Unibody AISI 304 stainless steel
Rounded internal corners
CFC free highdensity polyurethane insulation
Evaporator with cataphoresis rust protection
Door hinge on left side
Heated door perimeter
Heated core probe installed on the door
Magnetic front panel
Front-access electrical box

CYCLES AND SOFTWARE

Probe cycles
Time cycles
Singleprobe cascade cycles
Multiprobe cascade cycles
Timer cycles
Quick start
Customizable parameters
Multiple and customizable cycle stages
Adjustable fan speed
Cookbook
HACCP data collection

STANDARD EQUIPMENT

External drip tray
Machine on feet
Multi-point heated core probe
Door spacer
Ethernet port
Humidity generator
Wi-Fi connection

OPTIONALS

Right hinged door
Machine with wheels
Condenser filter
4 probes predisposition
Ozone generator
Wooden cage packaging
Wooden crate packaging

TECHNICAL DATA



	PlugIn Air	Remote	H2O PlugIn	CO2 provision
Temperature range [°C]			-40/+85	
Cooling capacity (evap. -10°C / cond. 45°C) [W]	4822	-	4822	-
Required cooling capacity [W]	-	4821	-	4821
ø liquid line ["] [mm]	-	3/8" [10]	-	3/8" [10]
ø suction line ["] [mm]	-	1/2" [12]	-	1/2" [12]
Condensation	Air cooled	Remote	Water cooled	Remote
Refrigerant gas	R290	R404A/R452A	R290	CO2
GWP	3	3922	3	1
Climatic class	5	5	5	5
Power supply [V/ph/Hz]	380-420/3N/50	220-240/1N/50	380-420/3N/50	220-240/1N/50
Max absorption cold cycles [W/A]	3334/9,55	488/4,55	3084/9,55	488/4,55
Max absorption hot cycles [W/A]	4250/11,6	4250/11,6	4250/11,6	4250/11,6
Blast chilling capacity (+90°C/+3°C) [kg]	68	-	68	-
Freezing capacity (+90°C/-18°C) [kg]	52	-	52	-
Inside dimensions WxDxH [mm]	650x433x1210	650x433x1210	650x433x1210	650x433x1210
External dimensions WxDxH [mm]	750x864x2020	750x864x2020	750x864x2020	750x864x2020
Internal capacity [L]	341	341	341	341
Packing volume [m3]	1,6	1,6	1,6	1,6
Gross weight [kg]	261	225	261	225
Net weight [kg]	246	210	246	210
Gas charge [g]	2x150	-	2x105	-
Packaging dimensions WxDxH [mm]	790x905x2170	790x905x2170	790x905x2170	790x905x2170
Packaging dimensions of the second package WxDxH [mm]	-	-	-	-

EN22042

65°C / +10°C	kWh/Kg	0,065	65°C / -18°C	kWh/Kg	0,253
	min	88		min	270
	Kg	75		Kg	60

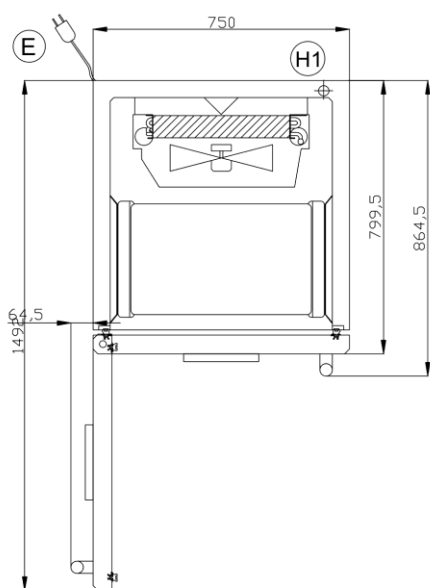
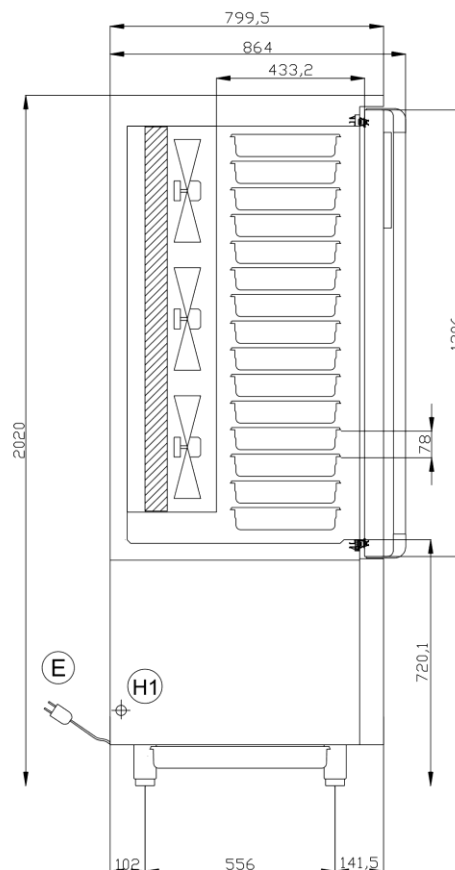
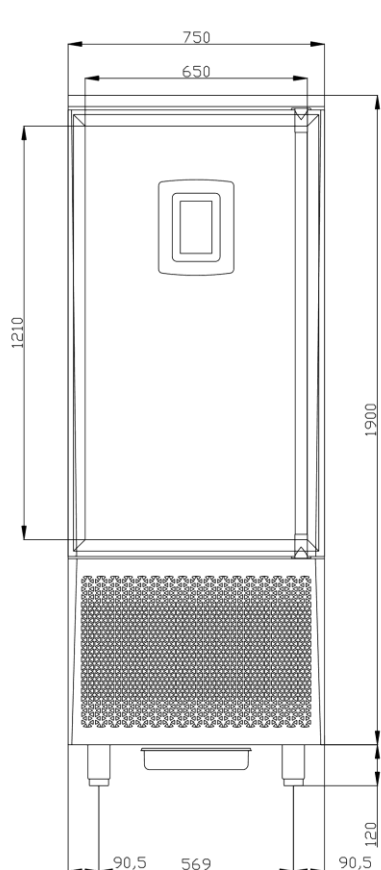

GASTRONOMY

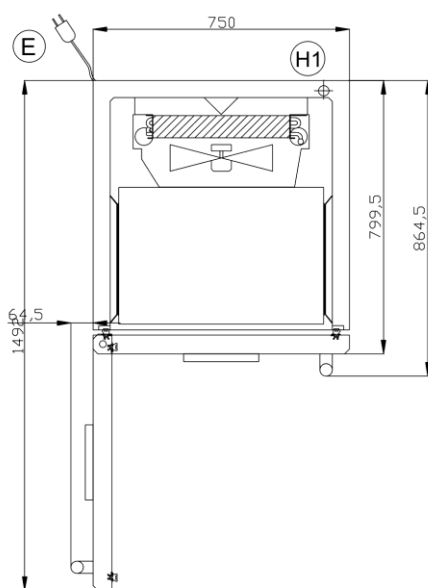
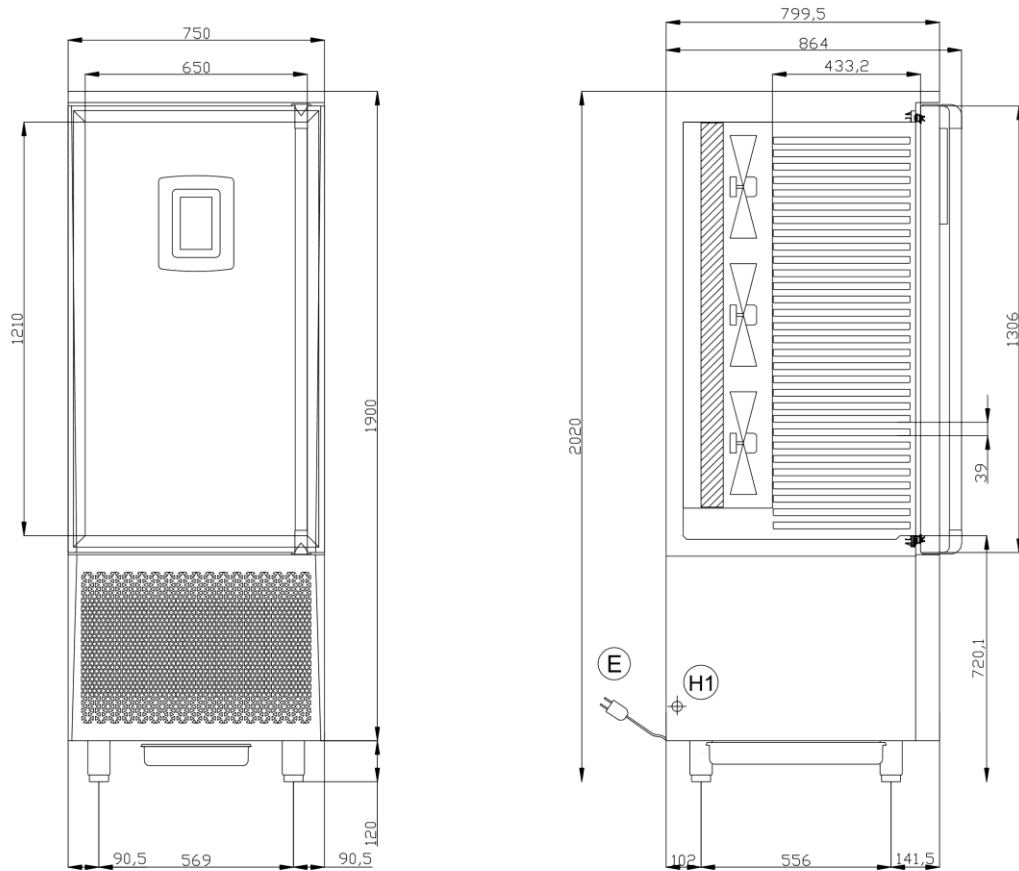

-  H MIN 120
H MAX 165
-  CONNESSIONE ELETTRICA
ELECTRICAL CONNECTION
-  CONNESSIONE INGRESSO H2O BOILER
WATER INLET CONNECTION BOILER

PASTRY



-  H MIN 120
H MAX 165
-  CONNESSIONE ELETTRICA
ELECTRICAL CONNECTION
-  CONNESSIONE INGRESSO H2O BOILER
WATER INLET CONNECTION BOILER

ICE-CREAM

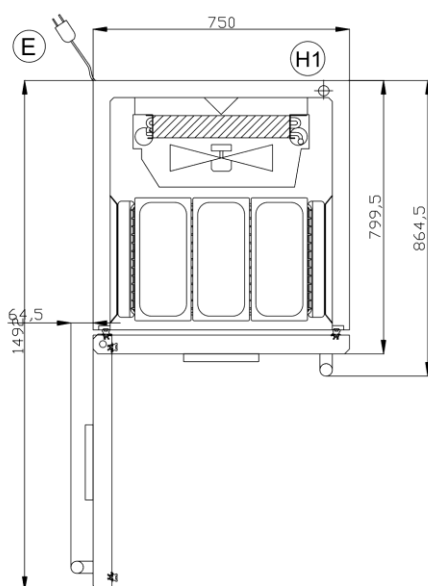
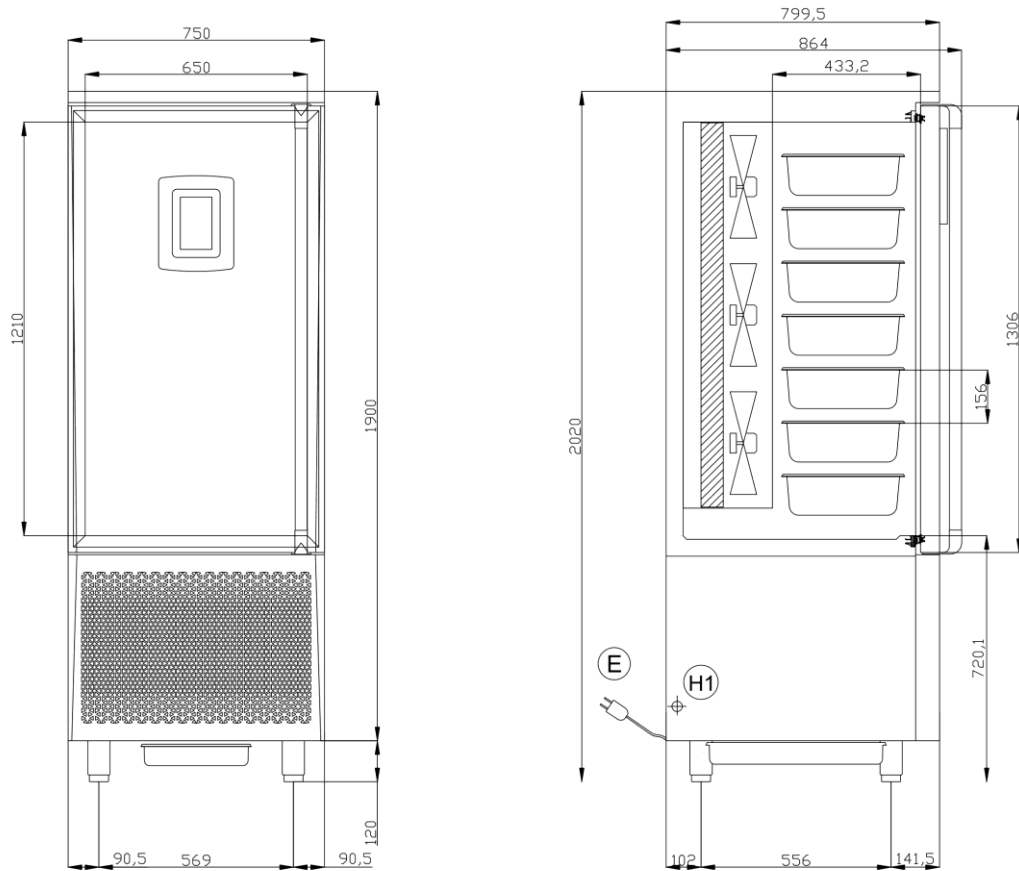

-  H MIN 120
H MAX 165
- (E)** CONNESSIONE ELETTRICA
ELECTRICAL CONNECTION
- (H1)** CONNESSIONE INGRESSO H2O BOILER
WATER INLET CONNECTION BOILER