

# PLUS 5



## Capacity

### Kg

23	+90°C	↓
	+3°C	
18	+90°C	↓
	-18°C	

## Trays

78	Trays pitch [mm]
5	GN 1/1 (H40 - 65)
10	GN 1/1 (H20)
10	EN 60/40

## Functions

Shock Freezing

Blast chilling

Ice cream hardening

Fish sanitation

Pastry

Thawing

Low temp cooking

Retherm

Proofing

Bottle cooling

Pre-cooling

Pre-heating

Cell sanitizing

Cell drying

Hot gas defrosting

## CONSTRUCTION FEATURES

7" touch screen controller

Unibody AISI 304 stainless steel

Rounded internal corners

CFC free highdensity polyurethane insulation

Evaporator with cataphoresis rust protection

Door hinge on left side

Heated door perimeter

Heated core probe installed on the door

Magnetic front panel

Front-access electrical box

## CYCLES AND SOFTWARE

Probe cycles

Time cycles

Singleprobe cascade cycles

Multiprobe cascade cycles

Timer cycles

Quick start

Customizable parameters

Multiple and customizable cycle stages

Adjustable fan speed

Cookbook

HACCP data collection

## STANDARD EQUIPMENT

External drip tray

Machine on feet

Multi-point heated core probe

Door spacer

Ethernet port

Humidity generator

Wi-Fi connection

## OPTIONALS

Right hinged door

Machine with wheels

Condenser filter

4 probes predisposition

Ozone generator

Wooden cage packaging

Wooden crate packaging

## TECHNICAL DATA



	PlugIn Air	Remote	H2O PlugIn	CO2 provision
Temperature range [°C]			-40/+85	
Cooling capacity (evap. -10°C / cond. 45°C) [W]	2069	-	2069	-
Required cooling capacity [W]	-	2069	-	2069
ø liquid line ["] [mm]	-	1/4" [6]	-	1/4" [6]
ø suction line ["] [mm]	-	3/8" [10]	-	3/8" [10]
Condensation	Air cooled	Remote	Water cooled	Remote
Refrigerant gas	R290	R404A/R452A	R290	CO2
GWP	3	3922	3	1
Climatic class	5	5	5	5
Power supply [V/ph/Hz]	220-240/1N/50	220-240/1N/50	220-240/1N/50	220-240/1N/50
Max absorption cold cycles [W/A]	1269/7,59	172/1,55	1205/6,55	172/1,55
Max absorption hot cycles [W/A]	1550/8,15	1550/8,15	1550/8,15	1550/8,15
Blast chilling capacity (+90°C/+3°C) [kg]	23	-	23	-
Freezing capacity (+90°C/-18°C) [kg]	18	-	18	-
Inside dimensions WxDxH [mm]	650x433x410	650x433x410	650x433x410	650x433x410
External dimensions WxDxH [mm]	750x864x970	750x864x970	750x864x970	750x864x970
Internal capacity [L]	115	115	115	115
Packing volume [m3]	0,8	0,8	0,8	0,8
Gross weight [kg]	139	121	139	121
Net weight [kg]	124	106	124	106
Gas charge [g]	1x150	-	1x105	-
Packaging dimensions WxDxH [mm]	790x905x1120	790x905x1120	790x905x1120	790x905x1120
Packaging dimensions of the second package WxDxH [mm]	-	-	-	-

## EN22042

65°C / +10°C	kWh/Kg	0,076	65°C / -18°C	kWh/Kg	0,25
	min	88		min	265
	Kg	25		Kg	20

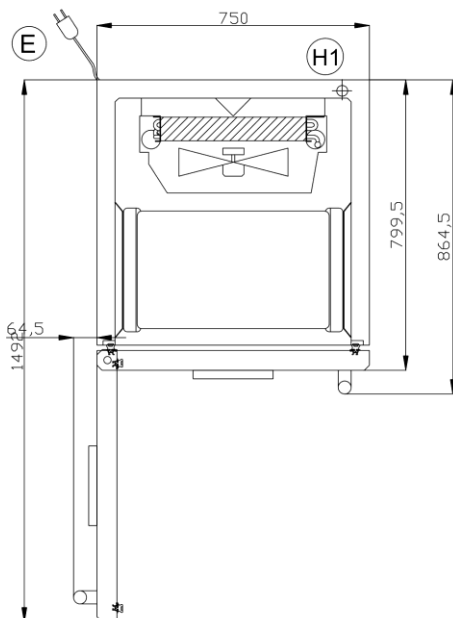
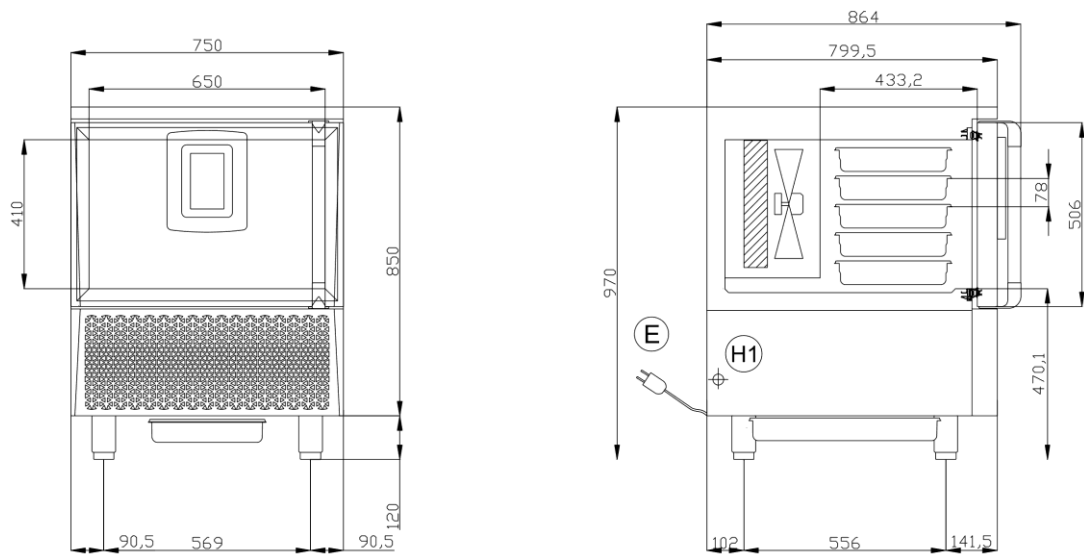
## GASTRONOMY



-  H MIN 120  
H MAX 165
-  CONNESSIONE ELETTRICA  
ELECTRICAL CONNECTION
-  CONNESSIONE INGRESSO H2O BOILER  
WATER INLET CONNECTION BOILER

## PASTRY

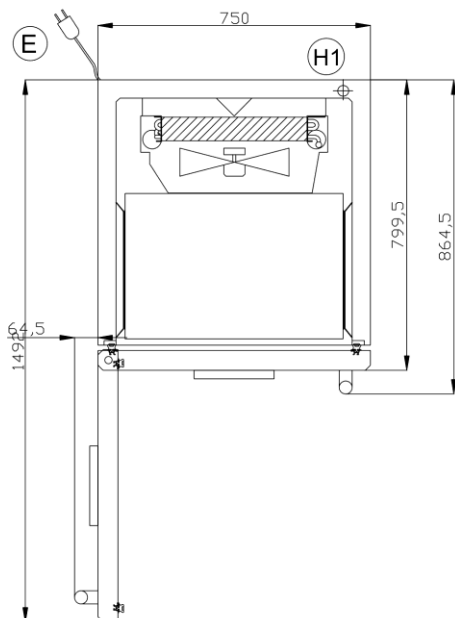
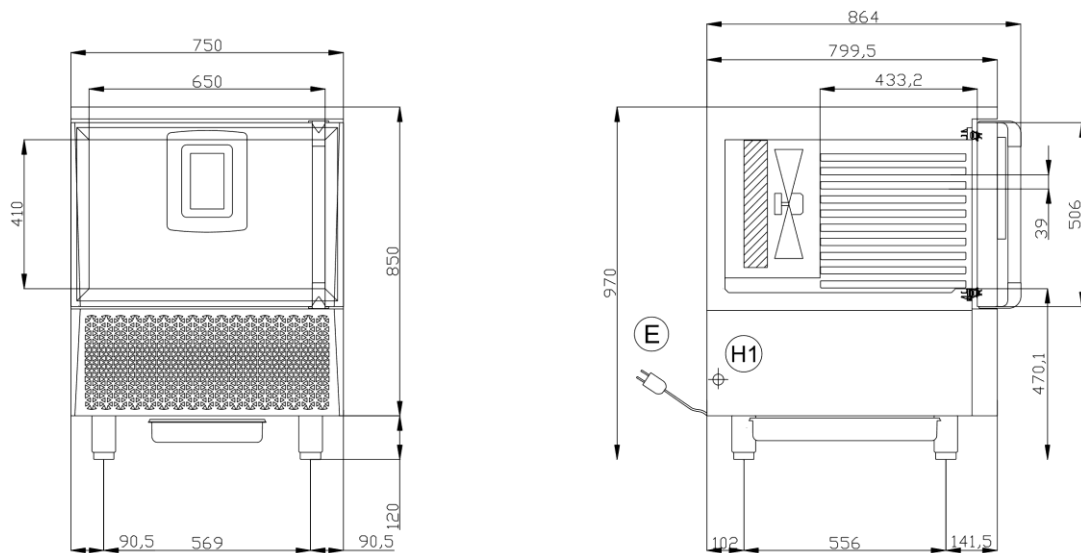

H MIN 120  
H MAX 165

(E) CONNESSIONE ELETTRICA  
ELECTRICAL CONNECTION

(H1) CONNESSIONE INGRESSO H2O BOILER  
WATER INLET CONNECTION BOILER

## ICE-CREAM

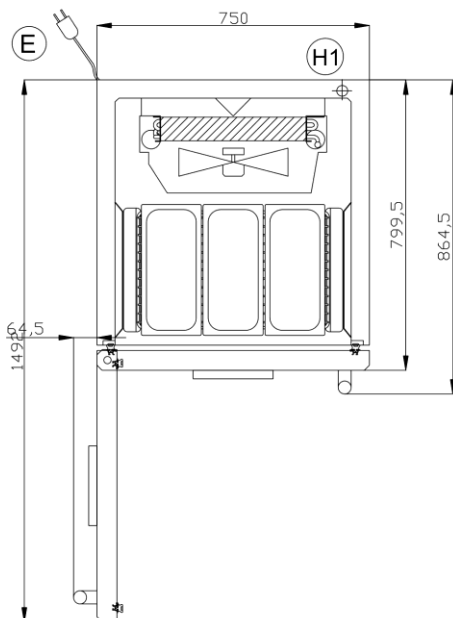
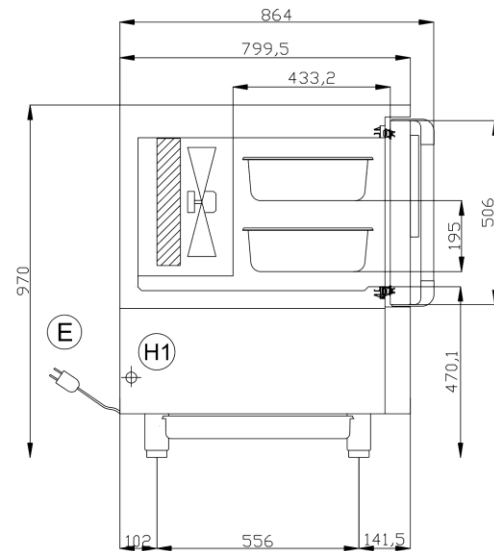
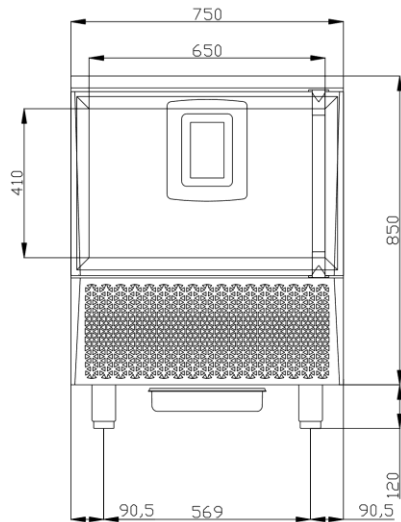

 H MIN 120  
H MAX 165

 CONNESSIONE ELETTRICA  
ELECTRICAL CONNECTION

 CONNESSIONE INGRESSO H2O BOILER  
WATER INLET CONNECTION BOILER