

3240 Impinger Oven

Models

- 3240 Natural Gas
- 3240 LP Gas
- 3240 Electric



Standard Features

Air Impingement

Air impingement uses hot air under pressure which surrounds food with small jets of hot air. This allows for rapid heating, cooking, baking and crisping of foods, two to four times faster than conventional ovens, depending on food product cooked.

Uniform Heating

Uniform heating/cooking of food products offers a wide tolerance for rapid baking at a variety of temperatures.

Variable Speed Continuous Cook Platform

Variable speed continuous cook platform moves product through the oven one after another improving product flow during cooking eliminating the need for constant tending resulting in reduced labor.

Customized Air Flow

Customer specific finger panels allow for heat to be adjusted and controlled by zoning for menu flexibility.

Specifications

General:

- Stainless steel top, front and sides
- 40" (1016 mm) wide baking chamber
- 32" (813 mm) wide, 73" (1854 mm) long conveyor belt with product stop
- Front removable fingers
- Stackable up to three high
- Front loading glass access door with cool touch handle
- 3" (76.2mm) conveyor opening
- Includes oven start-up/check-out by Welbilt authorized service agent

Controls:

- Adjustable temperature from 250°F (121°C) to 600°F (316°C) to accommodate a wide range of products
- Adjustable conveyor speed from 1 to 30 minutes
- Digital controls with easy to read display panel controls temperature, belt speed and diagnostics

Cooking:

- FastBake technology - reduces cook time by up to an additional 30% with no food quality loss or noise increase
- Customer specific finger set-up for menu flexibility

Options:

- 6' flexible gas connector
- 16" entry and exit shelves
- Split belt
- Folding conveyor
- High stand with casters (single or double stack)
- Low stand with casters (triple stack)

NOTE: New oven installations require an oven top and stand be included with the order. Must specify belt direction when ordering.



3240 Impinger Oven

Gas Supply Pressure Recommendations

Gas Type	Supply (Inlet) Pressure (mbar)	Recommended Minimum Gas Pipe Size
Natural	7-14" WC (2.2 kPa / 22.4 mbar - 3.5 kPa / 34.9 mbar)	2" (51 mm)
LP	11-14" WC (2.7 kPa / 27.36 mbar - 3.5 kPa / 34.9 mbar)	2" (51 mm)

*Gas supply pressures are dependent on local gas type and on all applicable local codes. Agency approved flexible connection to each oven must be minimum 3/4" (19 mm) NPT and length must not exceed six (6) feet (1829 mm).

Electrical Service

Each oven deck requires voltage, phase and hertz as indicated by model number. Neutral must be grounded at electrical service and receptacle properly polarized. Gas 120V units have a cord with NEMA 5-15 plug. All other models have terminal block connections. It is recommended that a separate circuit breaker be provided for each oven deck.

Recommended Minimum Clearances

Rear of oven to combustible surface: 6" (152 mm). Clearance on right side from other cooking equipment: 24" (610 mm). Clearance required to remove conveyor for cleaning: 11' (3553 mm).

Warranty

All new 3240 Impinger ovens installed in the United States and Canada come with a three (3) year parts and labor warranty starting from the date of start-up/check-out. All ovens installed in locations other than in the US and Canada are warranted for one (1) year parts and ninety (90) days labor starting from the date of start-up/check-out. Start-up/check-out must occur within 18 months of date of manufacture.

General Information

	WIDTH	DEPTH	HEIGHT SGL STACK	HEIGHT DBL STACK	HEIGHT TPL STACK	WEIGHT	SHIPPING WEIGHT	APPROXIMATE SHIPPING DIMENSIONS				
								CU. FT.	W	D	H	CLASS
All 3240 Models	77.6" (1972 mm)	60.1" (1527 mm)	46" (1168 mm)	64.6" (1641 mm)	71.8" (1824 mm)	750 lbs	780 lbs	97.2	86	66	36	85

3240-000-L-K2300

**Language/Agency/
(Electric For Gas Ovens Only)**
This is only a partial list of available configurations
0: English/French/US/120/60/1
1: English/French/US/120/60/1*
2: English/CE/230/50/1
B: French/CE/230/50/1
D: Italian/CE/230/50/1
E: Spanish/CE/230/50/1
G: Spanish/US/120/60/1
J: Danish/CE/230/50/1
*Export Crating

Belt Type
0 = Solid Belt
5 = Split Belt

Finger Setup
K2350 = General Market L to R
K2351 = General Market R to L

Heating Type
N = Natural (120,000 BTU/Hr)
L = LP (120,000 BTU/Hr)
T=Butane/Towne/Other

Electric (For Non-Gas Ovens):
B: 400Y/3/50 | R: 208/3/60
D: 380Y/3/50 | S: 480/460/440/3/60
G: 415Y/3/50 | V: 240/3/60
W: 220/3/60

Customer Configuration
0 = General Market

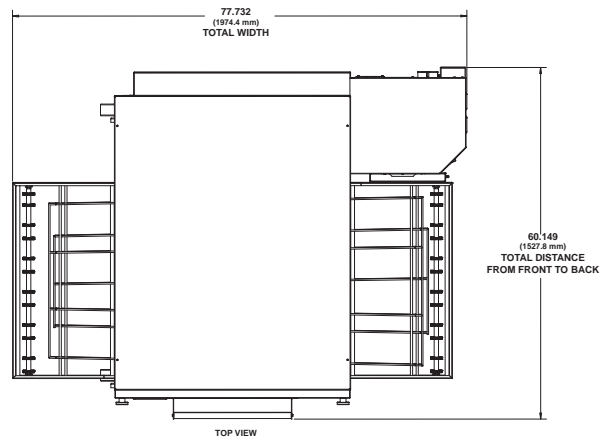
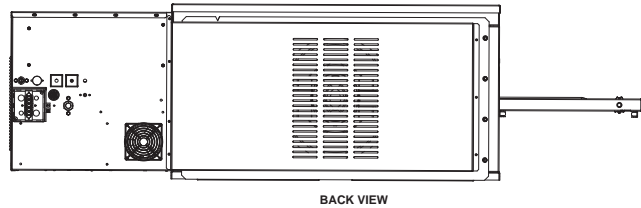
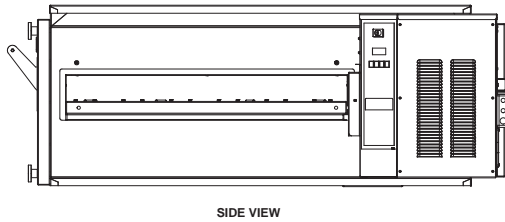
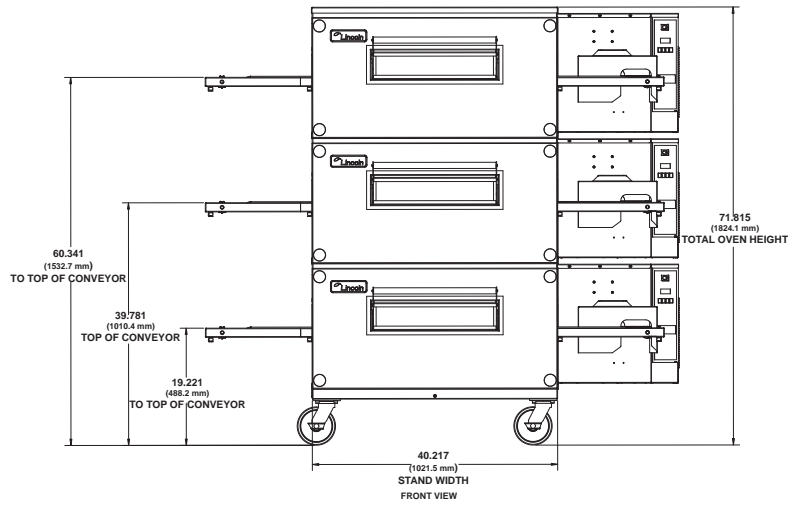
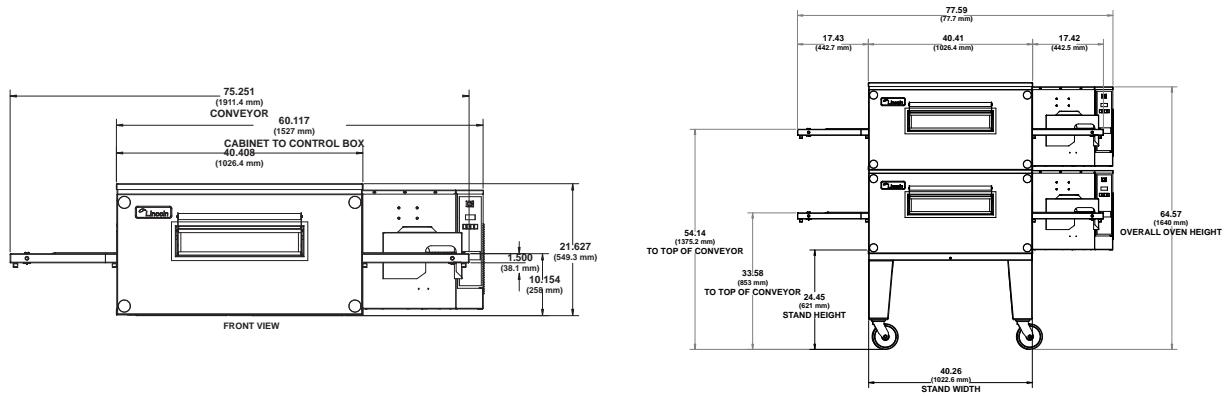

Capacity Estimates | Pies Per Hour

Pie Size	BAKE TIME								
	3 min.	3½ min.	4 min.	4½ min.	5 min.	5½ min.	6 min.	6½ min.	7 min.
12" (30 cm)	182	155	135	120	108	99	90	84	78
14" (36 cm)	115	99	87	77	69	63	58	53	50
16" (41 cm)	101	87	76	67	61	55	51	47	44

Ventilation Requirements

Ventilation is required for 3240 Impinger conveyor ovens. Hood specification, design and installation must meet IMC 2009/2012 Sec 5.7 and other requirements. Pizza Ovens are Light Duty Appliances for determining code compliance. If a Type I hood with Fire Suppression is required, proper interlocks of controls for the oven and the vent hood must be approved per IMC 2012 or equivalent. The vent/extraction application for this oven and overall final installation is determined by the authority having jurisdiction per NFPA-96. Carbon monoxide levels must be less than 10 ppm in the space around the oven.

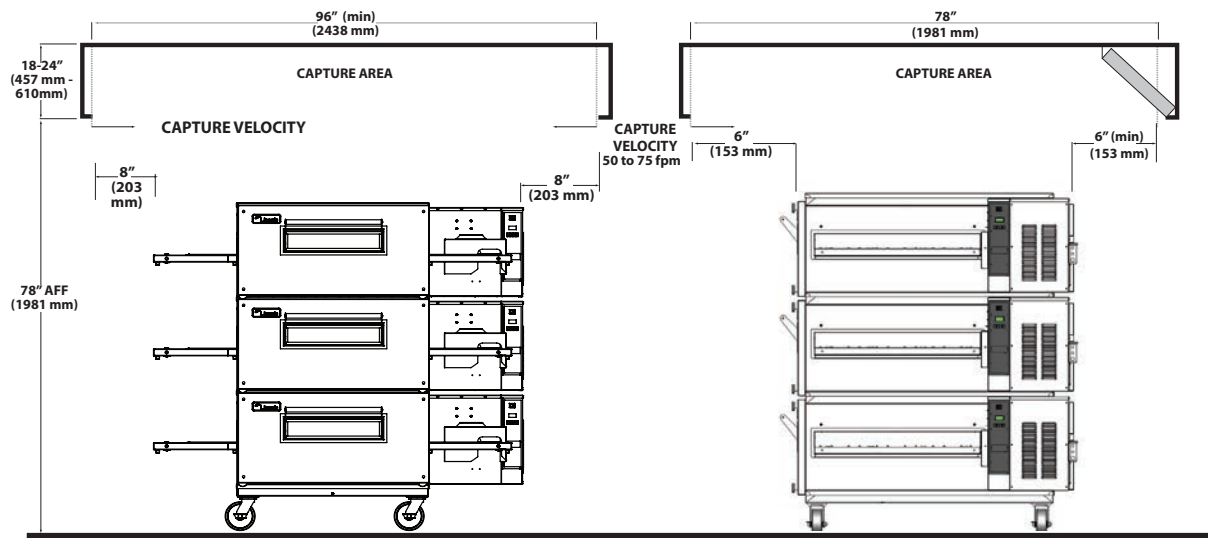

3240 Impinger Oven

1. Use of a Type II hood is permitted with actual product use defined as Light Duty according to the most current International Mechanical Code. However, application and overall final installation is determined per local codes.
2. Recommend 1000-1600 CFM Exhaust Rate to provide complete extraction of vapors and heat.
3. The capture velocity across the lower edge of the canopy must be sufficient to direct cooking vapors and oven heat into the hood. This is to be inward 50 to 75 FPM at sides and front. This capture velocity is to be verified on site with all ovens operating at set temperature.
4. Certified grease extraction filters should be used at the exhaust area of the hood.
5. Dimensions shown are for ovens without extension shelves. The outside end of the conveyor frame should be a minimum of 8 inches inside the canopy as shown.
6. The ovens are to be centered in the canopy space left-to-right and front-to-back if possible.
7. A minimum 6 inch space behind the oven is recommended for utilities.
8. If make-up air is provided outside of the canopy through diffusers, they should be directed straight down, not at the oven. Room air diffusers must not be directed toward the oven and should be positioned a minimum of 3 ft. from the perimeter of the hood.

Lincoln reserves the right to make changes to the design or specifications without prior notice.