



XEVC-0311-E1RM

Project _____

Item _____

Quantity _____

Date _____

Model
CHEFTOP MIND.Maps™ ONE COUNTERTOP

 **Energy efficiency 19.7 kWh/day - 0 kg CO₂/day***

*More details on the last page.

Combi oven	Electric
3 trays GN 1/1	Hinge on the left side
9.5" Touch control panel	
Voltage: 380-415V 3N~ / 220-240V 3~ / 220-240V 1N~	

Description

Technologically advanced combi oven able to handle different cooking processes (dehydrating, steaming, low temperature cooking, sous vide cooking, roasting, grilling, pan frying, regeneration regeneration and plate regeneration) and baking process (fresh and frozen bakery and pastry). Thanks to Unox Intensive Cooking technology that guarantees perfect results for each process.



Standard cooking features

Programs

- 1000+ Programs
- **MIND.Maps™**: draw the cooking processes directly on the display

Manual cooking

- **Temperature**: 30 °C – 260 °C
- Up to 9 cooking steps
- **CLIMA.Control**: humidity or dry air set by 10%
- Delta T cooking with core probe

Advanced and automatic cooking features

Unox Intensive Cooking

- **DRY.Maxi™**: rapidly extracts the humidity from the cooking chamber
- **STEAM.Maxi™**: produces saturated steam
- **AIR.Maxi™**: manage fans auto-reverse and pulse function
- **CLIMALUX™**: total control of the humidity in the cooking chamber





XEVC-0311-E1RM

Key features

- **ROTOR.Klean™**: automatic washing system
- Cooking chamber in high-resistance AISI 304 stainless steel with rounded edges
- Double glass
- Cooking chamber lighting through LED lights embedded in the door
- Tray supports with anti-tip system
- Drip collection system integrated in the door which works even when the door is open
- 4-speed fan system and high-performance heating elements
- Integrated DET&Rinse™ detergent container
- **Wi-Fi / USB data**: download/upload HACCP data
- **Wi-Fi / USB data**: download/upload programs

App and web services

- **Data Driven Cooking app & webapp**: check and monitor in real-time the operating conditions of your ovens, create and share new recipes. Artificial intelligence transforms consumption data into useful information and allows you to increase daily profits
- **Top Training app**: download the Unox Top.Training app and learn step by step all the secrets of your new oven's control panel

Accessories

- **Ventless hood**: steam condensing hood
- **Ventless hood with activated carbon filter**: steam condensing hood with activated carbon filter
- **SLOWTOP**: ideal solution for butchers and deli shops, that combines intense cooking processes with gentle ones, such as holding and night-time cooking
- **Neutral cabinet**: recommended solution to optimize your kitchen layout and always have everything in the right place
- **Stand**: the multifunctional support ideal for storing trays safely and placing your oven at the perfect height to work
- **QUICK.Load** and trolley system
- **Cooking Essentials**: special trays
- **DET&Rinse™ ECO**: eco formula for daily cleaning and the utmost respect for the environment. Ideal for mild level of dirt.
- **DET&Rinse™ ULTRAPLUS**: cleaning and rinse agents to combine maximum cleanliness with minimum consumption and long life for your oven
- **PURE / PURE.XL**: resin-based filtering system that eliminates from the water all substances that contribute to the formation of limescale inside the oven cooking chamber
- **PURE-RO**: Reverse osmosis system that eliminates Chlorides and limescale from water
- **Wi-Fi / Ethernet**: Connection board to keep the oven connected to Unox cloud, mandatory to extend the warranty

XEVC-0311-E1RM

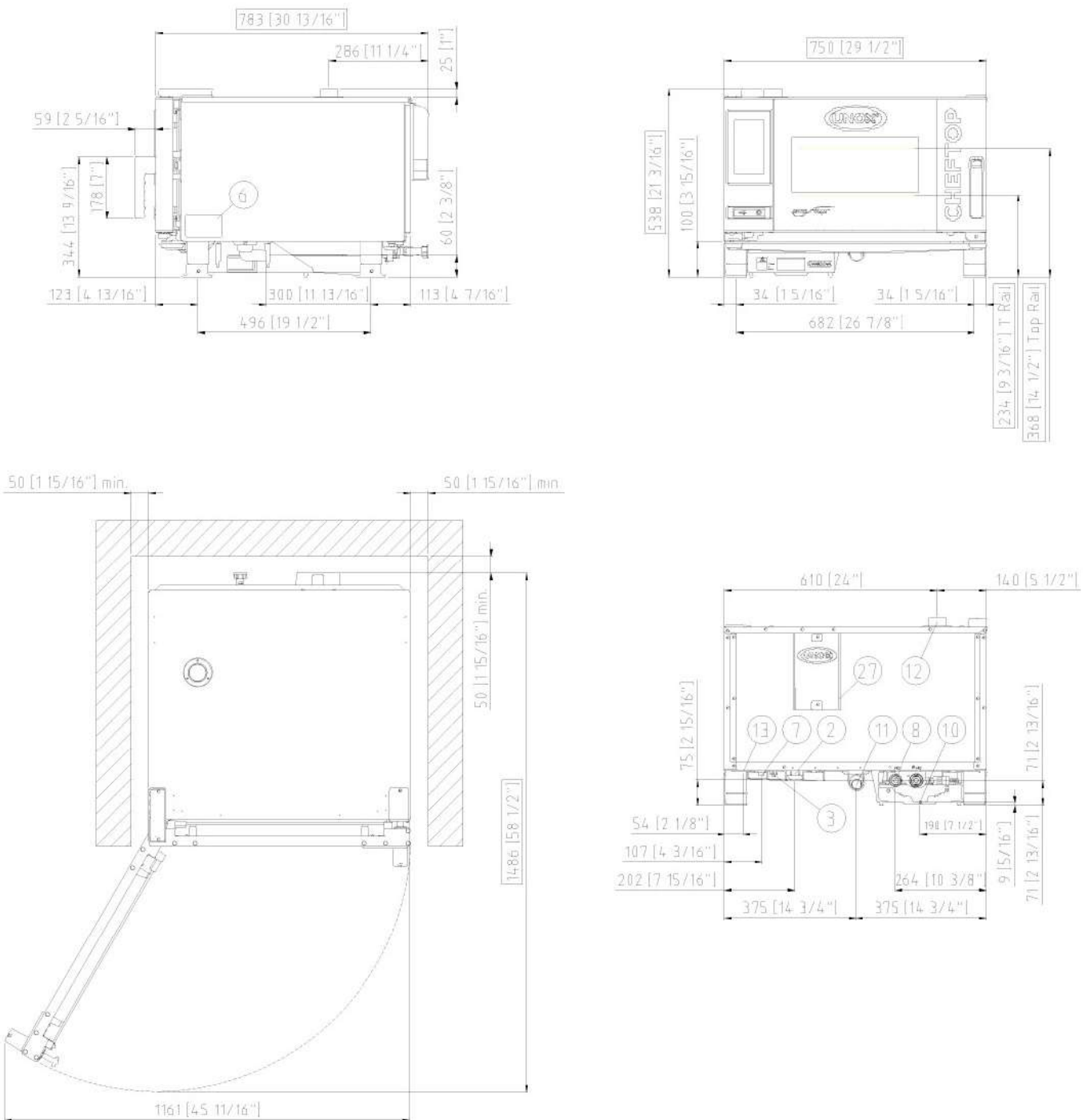

Dimensions and weight

Width	750 mm
Depth	783 mm
Height	538 mm
Net weight	54 kg
Tray pitch	67 mm

Connection positions

2	Terminal board power supply
3	Unipotential terminal
6	Technical data plate
7	Safety thermostat
8	3/4" female NPT water inlet
10	Rotor.KLEAN™ inlet

11	Chamber drain pipe
12	Hot fumes exhaust chimney
13	Accessories connection
27	Cooling air outlet



XEVC-0311-E1RM

Electrical power supply

STANDARD

Voltage	380-415 V
Phase	~3PH+N+PE
Frequency	50 / 60 Hz
Total power	5 kW
Max Amp draw	7 A
Required breaker size	16 A
Power cable requirements*	5G x 2,5 mm ²
Plug	NOT INCLUDED

OPTION A

Voltage	220-240 V
Phase	~3PH+PE
Frequency	50 / 60 Hz
Total power	5 kW
Max Amp draw	12 A
Required breaker size	16 A
Power cable requirements*	4G x 2,5 mm ²
Plug	NOT INCLUDED

OPTION B

Voltage	220-240 V
Phase	~1PH+N+PE
Frequency	50 / 60 Hz
Total power	5 kW
Max Amp draw	21 A
Required breaker size	25 A
Power cable requirements*	3G x 4 mm ²
Plug	NOT INCLUDED

*Recommended size - observe local ordinance.

Energy efficiency

Consumption

CO₂ emission

**The estimate includes only direct emissions produced by the oven. Indirect emissions can be reduced to zero by choosing to purchase energy from renewable sources.

Estimate based on daily use of the oven (300 days/year):

6 light loads of roast chickens (loaded at 20%), 1 full load of roast potatoes, 3 full loads cooking with steam 2 hours in an empty oven at 180 °C.

Estimated assuming the following weekly washing programs (42 weeks/year):

1 long wash, 1 medium wash.

Water Supply

USING A WATER SUPPLY THAT DOES NOT MEET UNOX'S MINIMUM WATER QUALITY STANDARDS WILL VOID ANY WARRANTY.

It is the responsibility of the purchaser to ensure that the incoming water supply is compliant with the listed specifications through adequate treatment measures.

Line pressure: Drinking water inlet: 3/4" NPT*, line pressure: 22 to 87 psi; 1.5 to 6 Bar (29 psi; 2 Bar recommended)

Inflow water specifications

Free chlorine ≤ 0.5 ppm

Chloramine ≤ 0.1 ppm

pH 7 - 8.5

Electrical conductivity ≤ 1000 µS/cm

Total hardness ≤ 30° dH

Chlorides ≤ 120 ppm

Steam circuit: inflow water specifications

Total hardness ≤ 8 °dH

Chlorides ≤ 25 ppm

To avoid the formation of limescale the incoming water must have total hardness ≤ 8°dH.

*This value refers to daily steam cooking of 1-2 hours. In any case, if with a total hardness ≤ 8°dH there is still production of limescale, it is mandatory to treat the water in order to avoid limescale production. Unox recommends water treatment systems based on ion exchange resins. Water treatment systems based on polyphosphate are not allowed.

Installation requirements

Installations must comply with all local electrical systems, particularly as for minimum wire gauge required for field connection, hydraulic and ventilation supply. Exhaust and fume analysis must be performed in case of gas ovens.

Register to DDC Service to access data and product specifications.
www.ddc.unox.com



XEVC-0511-E1RM-LP

Project _____

Item _____

Quantity _____

Date _____

Model
CHEFTOP MIND.Maps™ ONE COUNTERTOP

 **Energy efficiency 26 kWh/day - 0 kg CO₂/day***
 *More details on the last page.

Combi oven	Electric
5 trays GN 1/1	Hinge on the left side
9.5" Touch control panel	
Voltage: 380-415V 3N~ / 220-240V 3~ / 220-240V 1~	

Description

Technologically advanced combi oven able to handle different cooking processes (dehydrating, steaming, low temperature cooking, sous vide cooking, roasting, grilling, pan frying, regeneration regeneration and plate regeneration) and baking process (fresh and frozen bakery and pastry). Thanks to Unox Intensive Cooking technology that guarantees perfect results for each process.



Standard cooking features

Programs

- 1000+ Programs
- **MIND.Maps™**: draw the cooking processes directly on the display

Manual cooking

- **Temperature**: 30 °C – 260 °C
- Up to 9 cooking steps
- **CLIMA.Control**: humidity or dry air set by 10%
- Delta T cooking with core probe

Advanced and automatic cooking features

Unox Intensive Cooking

- **DRY.Maxi™**: rapidly extracts the humidity from the cooking chamber
- **STEAM.Maxi™**: produces saturated steam
- **AIR.Maxi™**: manage fans auto-reverse and pulse function
- **CLIMALUX™**: total control of the humidity in the cooking chamber





XEVC-0511-E1RM-LP

Key features

- **ROTOR.Klean™**: automatic washing system
- Cooking chamber in high-resistance AISI 304 stainless steel with rounded edges
- Double glass
- Cooking chamber lighting through LED lights embedded in the door
- Tray supports with anti-tip system
- Drip collection system integrated in the door which works even when the door is open
- 4-speed fan system and high-performance heating elements
- Integrated DET&Rinse™ detergent container
- **Wi-Fi / USB data**: download/upload HACCP data
- **Wi-Fi / USB data**: download/upload programs

App and web services

- **Data Driven Cooking app & webapp**: check and monitor in real-time the operating conditions of your ovens, create and share new recipes. Artificial intelligence transforms consumption data into useful information and allows you to increase daily profits
- **Top Training app**: download the Unox Top.Training app and learn step by step all the secrets of your new oven's control panel

Accessories

- **Ventless hood**: steam condensing hood
- **Ventless hood with activated carbon filter**: steam condensing hood with activated carbon filter
- **SLOWTOP**: ideal solution for butchers and deli shops, that combines intense cooking processes with gentle ones, such as holding and night-time cooking
- **Neutral cabinet**: recommended solution to optimize your kitchen layout and always have everything in the right place
- **Stand**: the multifunctional support ideal for storing trays safely and placing your oven at the perfect height to work
- **QUICK.Load** and trolley system
- **Cooking Essentials**: special trays
- **DET&Rinse™ ECO**: eco formula for daily cleaning and the utmost respect for the environment. Ideal for mild level of dirt.
- **DET&Rinse™ ULTRAPLUS**: cleaning and rinse agents to combine maximum cleanliness with minimum consumption and long life for your oven
- **PURE / PURE.XL**: resin-based filtering system that eliminates from the water all substances that contribute to the formation of limescale inside the oven cooking chamber
- **PURE-RO**: Reverse osmosis system that eliminates Chlorides and limescale from water
- **Wi-Fi / Ethernet**: Connection board to keep the oven connected to Unox cloud, mandatory to extend the warranty

XEVC-0511-E1RM-LP

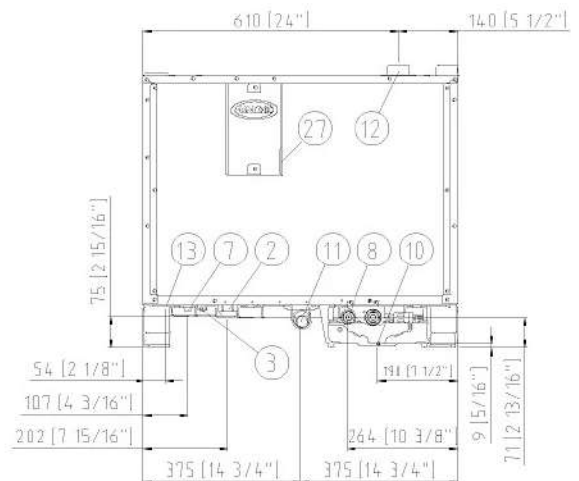
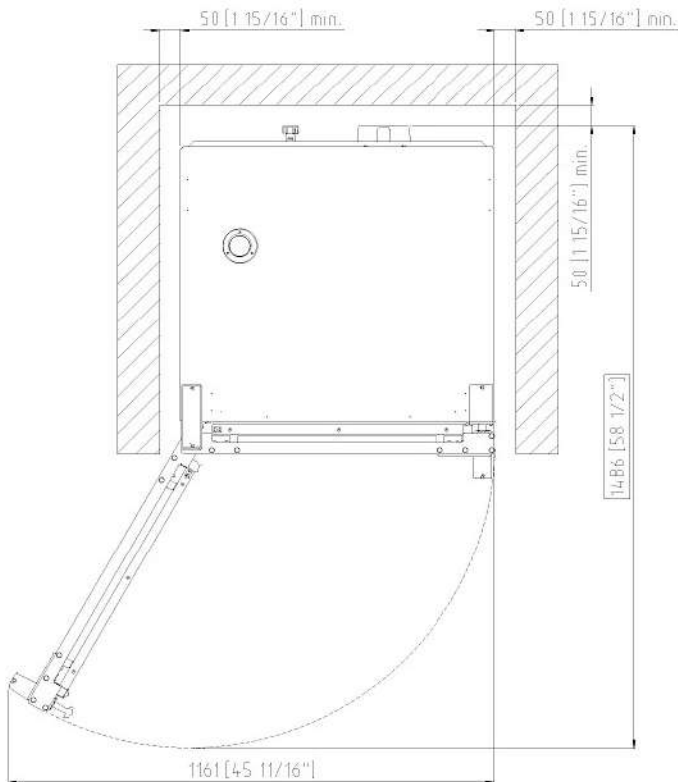
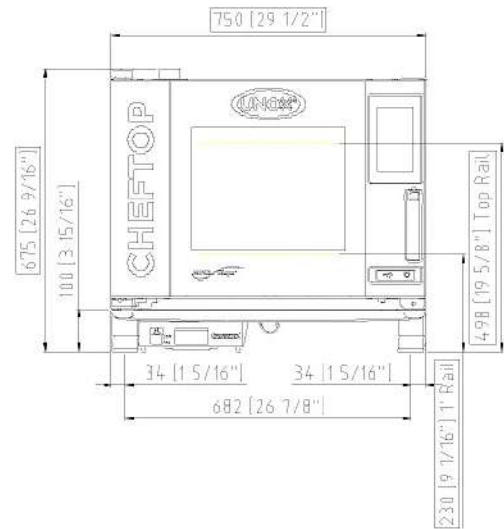
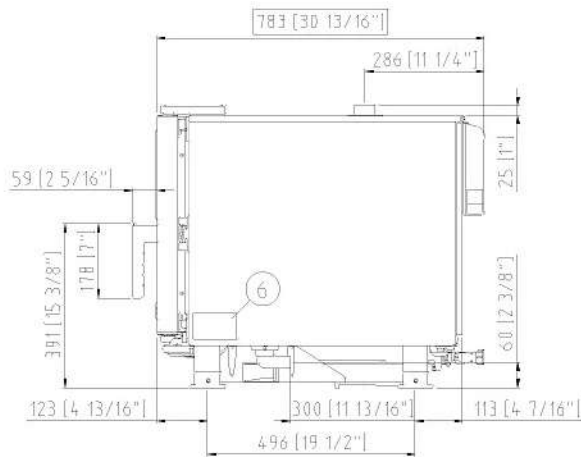

Dimensions and weight

Width	750 mm
Depth	783 mm
Height	675 mm
Net weight	66 kg
Tray pitch	67 mm

Connection positions

2	Terminal board power supply
3	Unipotential terminal
6	Technical data plate
7	Safety thermostat
8	3/4" female NPT water inlet
10	Rotor.KLEAN™ inlet

11	Chamber drain pipe
12	Hot fumes exhaust chimney
13	Accessories connection
27	Cooling air outlet



XEVC-0511-E1RM-LP

Electrical power supply

STANDARD

Voltage	380-415 V
Phase	~3PH+N+PE
Frequency	50 / 60 Hz
Total power	7 kW
Max Amp draw	11 A
Required breaker size	16 A
Power cable requirements*	5G x 2,5 mm ²
Plug	NOT INCLUDED

OPTION A

Voltage	220-240 V
Phase	~3PH+PE
Frequency	50 / 60 Hz
Total power	7 kW
Max Amp draw	18 A
Required breaker size	25 A
Power cable requirements*	4G x 4 mm ²
Plug	NOT INCLUDED

OPTION B

Voltage	220-240 V
Phase	~1PH+PE
Frequency	50 / 60 Hz
Total power	7 kW
Max Amp draw	30 A
Required breaker size	32 A
Power cable requirements*	3G x 4 mm ²
Plug	NOT INCLUDED

*Recommended size - observe local ordinance.

Energy efficiency

Consumption

CO₂ emission

**The estimate includes only direct emissions produced by the oven. Indirect emissions can be reduced to zero by choosing to purchase energy from renewable sources.

Estimate based on daily use of the oven (300 days/year):

6 light loads of roast chickens (loaded at 20%), 1 full load of roast potatoes, 3 full loads cooking with steam 2 hours in an empty oven at 180 °C.

Estimated assuming the following weekly washing programs (42 weeks/year):

1 long wash, 1 medium wash.

Water Supply

USING A WATER SUPPLY THAT DOES NOT MEET UNOX'S MINIMUM WATER QUALITY STANDARDS WILL VOID ANY WARRANTY.

It is the responsibility of the purchaser to ensure that the incoming water supply is compliant with the listed specifications through adequate treatment measures.

Line pressure: Drinking water inlet: 3/4" NPT*, line pressure: 22 to 87 psi; 1.5 to 6 Bar (29 psi; 2 Bar recommended)

Inflow water specifications

Free chlorine ≤ 0.5 ppm

Chloramine ≤ 0.1 ppm

pH 7 - 8.5

Electrical conductivity ≤ 1000 µS/cm

Total hardness ≤ 30° dH

Chlorides ≤ 120 ppm

Steam circuit: inflow water specifications

Total hardness ≤ 8 °dH

Chlorides ≤ 25 ppm

To avoid the formation of limescale the incoming water must have total hardness ≤ 8°dH.

*This value refers to daily steam cooking of 1-2 hours. In any case, if with a total hardness ≤ 8°dH there is still production of limescale, it is mandatory to treat the water in order to avoid limescale production. Unox recommends water treatment systems based on ion exchange resins. Water treatment systems based on polyphosphate are not allowed.

Installation requirements

Installations must comply with all local electrical systems, particularly as for minimum wire gauge required for field connection, hydraulic and ventilation supply. Exhaust and fume analysis must be performed in case of gas ovens.

Register to DDC Service to access data and product specifications.
www.ddc.unox.com



XEVC-0511-E1RM

Project _____

Item _____

Quantity _____

Date _____

Model
CHEFTOP MIND.Maps™ ONE COUNTERTOP

 **Energy efficiency 26 kWh/day - 0 kg CO₂/day***
 *More details on the last page.

Combi oven	Electric
5 trays GN 1/1	Hinge on the left side
9.5" Touch control panel	
Voltage: 380-415V 3N~ / 220-240V 3~ / 220-240V 1~	

Description

Technologically advanced combi oven able to handle different cooking processes (dehydrating, steaming, low temperature cooking, sous vide cooking, roasting, grilling, pan frying, regeneration regeneration and plate regeneration) and baking process (fresh and frozen bakery and pastry). Thanks to Unox Intensive Cooking technology that guarantees perfect results for each process.



Standard cooking features

Programs

- 1000+ Programs
- **MIND.Maps™**: draw the cooking processes directly on the display

Manual cooking

- **Temperature**: 30 °C – 260 °C
- Up to 9 cooking steps
- **CLIMA.Control**: humidity or dry air set by 10%
- Delta T cooking with core probe

Advanced and automatic cooking features

Unox Intensive Cooking

- **DRY.Maxi™**: rapidly extracts the humidity from the cooking chamber
- **STEAM.Maxi™**: produces saturated steam
- **AIR.Maxi™**: manage fans auto-reverse and pulse function
- **CLIMALUX™**: total control of the humidity in the cooking chamber





XEVC-0511-E1RM

Key features

- **ROTOR.Klean™:** automatic washing system
- Cooking chamber in high-resistance AISI 304 stainless steel with rounded edges
- Double glass
- Cooking chamber lighting through LED lights embedded in the door
- Tray supports with anti-tip system
- Drip collection system integrated in the door which works even when the door is open
- 4-speed fan system and high-performance heating elements
- Integrated DET&Rinse™ detergent container
- **Wi-Fi / USB data:** download/upload HACCP data
- **Wi-Fi / USB data:** download/upload programs

App and web services

- **Data Driven Cooking app & webapp:** check and monitor in real-time the operating conditions of your ovens, create and share new recipes. Artificial intelligence transforms consumption data into useful information and allows you to increase daily profits
- **Top Training app:** download the Unox Top.Training app and learn step by step all the secrets of your new oven's control panel

Accessories

- **Ventless hood:** steam condensing hood
- **Ventless hood with activated carbon filter:** steam condensing hood with activated carbon filter
- **SLOWTOP:** ideal solution for butchers and deli shops, that combines intense cooking processes with gentle ones, such as holding and night-time cooking
- **Neutral cabinet:** recommended solution to optimize your kitchen layout and always have everything in the right place
- **Stand:** the multifunctional support ideal for storing trays safely and placing your oven at the perfect height to work
- **QUICK.Load** and trolley system
- **Cooking Essentials:** special trays
- **DET&Rinse™ ECO:** eco formula for daily cleaning and the utmost respect for the environment. Ideal for mild level of dirt.
- **DET&Rinse™ ULTRAPLUS:** cleaning and rinse agents to combine maximum cleanliness with minimum consumption and long life for your oven
- **PURE / PURE.XL:** resin-based filtering system that eliminates from the water all substances that contribute to the formation of limescale inside the oven cooking chamber
- **PURE-RO:** Reverse osmosis system that eliminates Chlorides and limescale from water
- **Wi-Fi / Ethernet:** Connection board to keep the oven connected to Unox cloud, mandatory to extend the warranty

XEVC-0511-E1RM

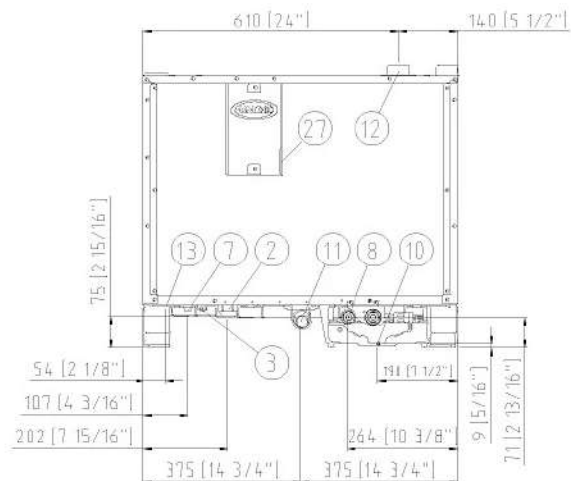
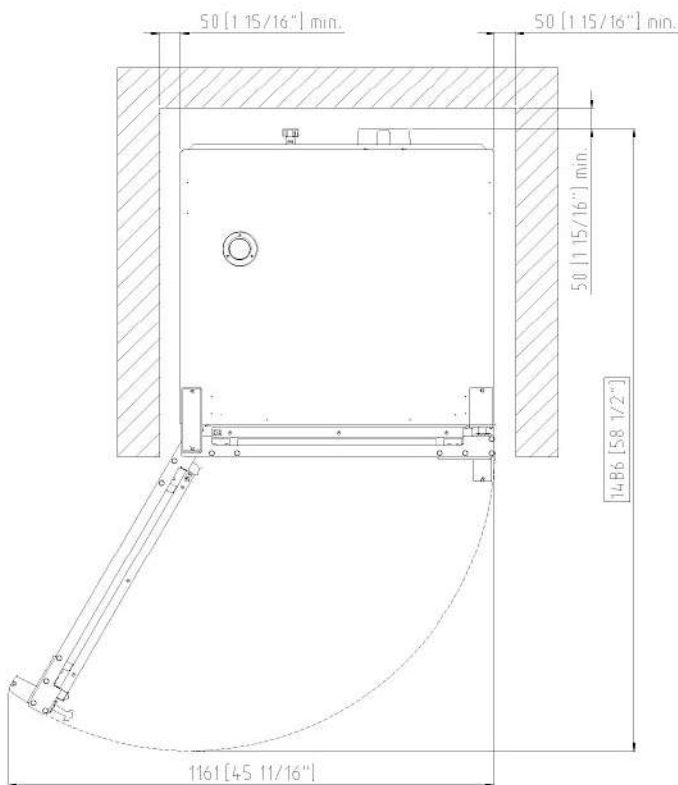
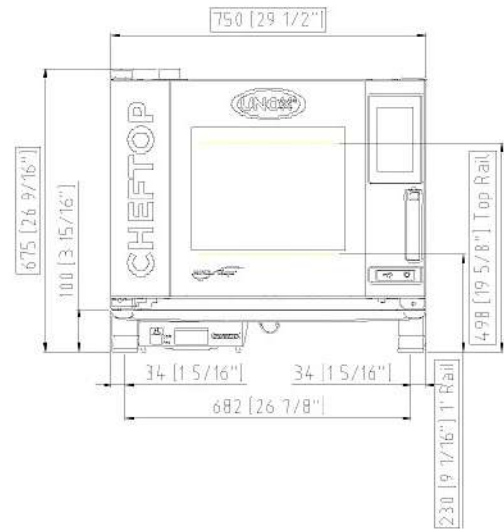
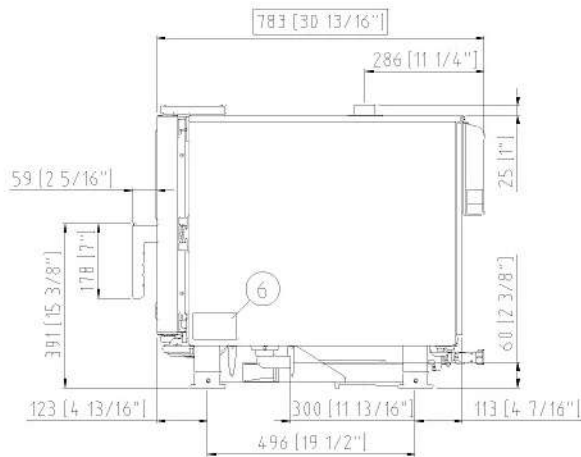

Dimensions and weight

Width	750 mm
Depth	783 mm
Height	675 mm
Net weight	66 kg
Tray pitch	67 mm

Connection positions

2	Terminal board power supply
3	Unipotential terminal
6	Technical data plate
7	Safety thermostat
8	3/4" female NPT water inlet
10	Rotor.KLEAN™ inlet

11	Chamber drain pipe
12	Hot fumes exhaust chimney
13	Accessories connection
27	Cooling air outlet



XEVC-0511-E1RM

Electrical power supply

STANDARD

Voltage	380-415 V
Phase	~3PH+N+PE
Frequency	50 / 60 Hz
Total power	9,3 kW
Max Amp draw	14 A
Required breaker size	16 A
Power cable requirements*	5G x 2,5 mm ²
Plug	NOT INCLUDED

OPTION A

Voltage	220-240 V
Phase	~3PH+PE
Frequency	50 / 60 Hz
Total power	9,3 kW
Max Amp draw	24 A
Required breaker size	32 A
Power cable requirements*	4G x 4 mm ²
Plug	NOT INCLUDED

OPTION B

Voltage	220-240 V**
Phase	~1PH+PE
Frequency	50 / 60 Hz
Total power	9,3 kW
Max Amp draw	41 A
Required breaker size	50 A
Power cable requirements*	3G x 10 mm ²
Plug	NOT INCLUDED

**Electric connection kit

Item	XUC129
Voltage	220-240 V
Phase	~1PH+PE

*Recommended size - observe local ordinance.

Energy efficiency

Consumption

CO₂ emission

**The estimate includes only direct emissions produced by the oven. Indirect emissions can be reduced to zero by choosing to purchase energy from renewable sources.

Estimate based on daily use of the oven (300 days/year):

6 light loads of roast chickens (loaded at 20%), 1 full load of roast potatoes, 3 full loads cooking with steam 2 hours in an empty oven at 180 °C.

Estimated assuming the following weekly washing programs (42 weeks/year):

1 long wash, 1 medium wash.

Water Supply

USING A WATER SUPPLY THAT DOES NOT MEET UNOX'S MINIMUM WATER QUALITY STANDARDS WILL VOID ANY WARRANTY.

It is the responsibility of the purchaser to ensure that the incoming water supply is compliant with the listed specifications through adequate treatment measures.

Line pressure: Drinking water inlet: 3/4" NPT*, line pressure: 22 to 87 psi; 1.5 to 6 Bar (29 psi; 2 Bar recommended)

Inflow water specifications

Free chlorine ≤ 0.5 ppm

Chloramine ≤ 0.1 ppm

pH 7 - 8.5

Electrical conductivity ≤ 1000 µS/cm

Total hardness ≤ 30° dH

Chlorides ≤ 120 ppm

Steam circuit: inflow water specifications

Total hardness ≤ 8 °dH

Chlorides ≤ 25 ppm

To avoid the formation of limescale the incoming water must have total hardness ≤ 8°dH.

*This value refers to daily steam cooking of 1-2 hours. In any case, if with a total hardness ≤ 8°dH there is still production of limescale, it is mandatory to treat the water in order to avoid limescale production. Unox recommends water treatment systems based on ion exchange resins. Water treatment systems based on polyphosphate are not allowed.

Installation requirements

Installations must comply with all local electrical systems, particularly as for minimum wire gauge required for field connection, hydraulic and ventilation supply. Exhaust and fume analysis must be performed in case of gas ovens.

Register to DDC Service to access data and product specifications.
www.ddc.unox.com



XEVC-0711-E1RM

Project _____

Item _____

Quantity _____

Date _____

Model
CHEFTOP MIND.Maps™ ONE COUNTERTOP

 **Energy efficiency 34.7 kWh/day - 0 kg CO₂/day***
 *More details on the last page.

Combi oven	Electric
7 trays GN 1/1	Hinge on the left side
9.5" Touch control panel	
Voltage: 380-415V 3N~ / 220-240V 3~ / 220-240V 1~	



Description

Technologically advanced combi oven able to handle different cooking processes (dehydrating, steaming, low temperature cooking, sous vide cooking, roasting, grilling, pan frying, regeneration regeneration and plate regeneration) and baking process (fresh and frozen bakery and pastry). Thanks to Unox Intensive Cooking technology that guarantees perfect results for each process.

Standard cooking features

Programs

- 1000+ Programs
- **MIND.Maps™**: draw the cooking processes directly on the display

Manual cooking

- **Temperature**: 30 °C – 260 °C
- Up to 9 cooking steps
- **CLIMA.Control**: humidity or dry air set by 10%
- Delta T cooking with core probe

Advanced and automatic cooking features

Unox Intensive Cooking

- **DRY.Maxi™**: rapidly extracts the humidity from the cooking chamber
- **STEAM.Maxi™**: produces saturated steam
- **AIR.Maxi™**: manage fans auto-reverse and pulse function
- **CLIMALUX™**: total control of the humidity in the cooking chamber





XEVC-0711-E1RM

Key features

- **ROTOR.Klean™**: automatic washing system
- Cooking chamber in high-resistance AISI 304 stainless steel with rounded edges
- Double glass
- Cooking chamber lighting through LED lights embedded in the door
- Tray supports with anti-tip system
- Drip collection system integrated in the door which works even when the door is open
- 4-speed fan system and high-performance heating elements
- Integrated DET&Rinse™ detergent container
- **Wi-Fi / USB data**: download/upload HACCP data
- **Wi-Fi / USB data**: download/upload programs

App and web services

- **Data Driven Cooking app & webapp**: check and monitor in real-time the operating conditions of your ovens, create and share new recipes. Artificial intelligence transforms consumption data into useful information and allows you to increase daily profits
- **Top Training app**: download the Unox Top.Training app and learn step by step all the secrets of your new oven's control panel

Accessories

- **Ventless hood**: steam condensing hood
- **Ventless hood with activated carbon filter**: steam condensing hood with activated carbon filter
- **SLOWTOP**: ideal solution for butchers and deli shops, that combines intense cooking processes with gentle ones, such as holding and night-time cooking
- **Neutral cabinet**: recommended solution to optimize your kitchen layout and always have everything in the right place
- **Stand**: the multifunctional support ideal for storing trays safely and placing your oven at the perfect height to work
- **QUICK.Load** and trolley system
- **Cooking Essentials**: special trays
- **DET&Rinse™ ECO**: eco formula for daily cleaning and the utmost respect for the environment. Ideal for mild level of dirt.
- **DET&Rinse™ ULTRAPLUS**: cleaning and rinse agents to combine maximum cleanliness with minimum consumption and long life for your oven
- **PURE / PURE.XL**: resin-based filtering system that eliminates from the water all substances that contribute to the formation of limescale inside the oven cooking chamber
- **PURE-RO**: Reverse osmosis system that eliminates Chlorides and limescale from water
- **Wi-Fi / Ethernet**: Connection board to keep the oven connected to Unox cloud, mandatory to extend the warranty

XEVC-0711-E1RM

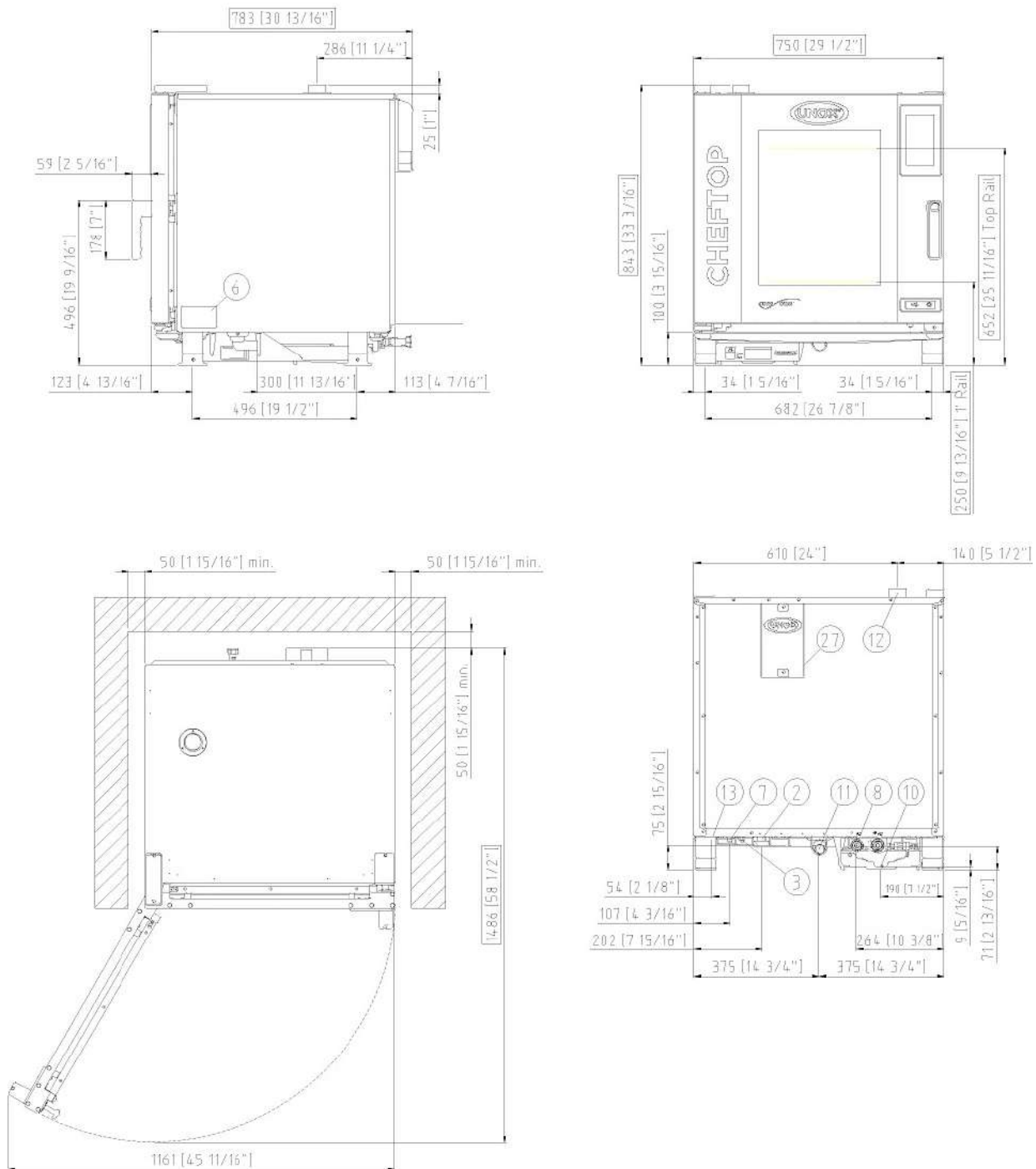

Dimensions and weight

Width	750 mm
Depth	783 mm
Height	843 mm
Net weight	82 kg
Tray pitch	67 mm

Connection positions

2	Terminal board power supply
3	Unipotential terminal
6	Technical data plate
7	Safety thermostat
8	3/4" female NPT water inlet
10	Rotor.KLEAN™ inlet

11	Chamber drain pipe
12	Hot fumes exhaust chimney
13	Accessories connection
27	Cooling air outlet



XEVC-0711-E1RM

Electrical power supply

STANDARD

Voltage	380-415 V
Phase	~3PH+N+PE
Frequency	50 / 60 Hz
Total power	11,7 kW
Max Amp draw	18 A
Required breaker size	25 A
Power cable requirements*	5G x 2,5 mm ²
Plug	NOT INCLUDED

OPTION A

Voltage	220-240 V
Phase	~3PH+PE
Frequency	50 / 60 Hz
Total power	11,7 kW
Max Amp draw	30 A
Required breaker size	32 A
Power cable requirements*	4G x 4 mm ²
Plug	NOT INCLUDED

OPTION B

Voltage	220-240 V**
Phase	~1PH+PE
Frequency	50 / 60 Hz
Total power	11,7 kW
Max Amp draw	51.5 A
Required breaker size	63 A
Power cable requirements*	3G x 10 mm ²
Plug	NOT INCLUDED

**Electric connection kit

Item	XUC129
Voltage	220-240 V
Phase	~1PH+PE

*Recommended size - observe local ordinance.

Energy efficiency

Consumption

CO₂ emission

**The estimate includes only direct emissions produced by the oven. Indirect emissions can be reduced to zero by choosing to purchase energy from renewable sources.

Estimate based on daily use of the oven (300 days/year):

6 light loads of roast chickens (loaded at 20%), 1 full load of roast potatoes, 3 full loads cooking with steam 2 hours in an empty oven at 180 °C.

Estimated assuming the following weekly washing programs (42 weeks/year):

1 long wash, 1 medium wash.

Water Supply

USING A WATER SUPPLY THAT DOES NOT MEET UNOX'S MINIMUM WATER QUALITY STANDARDS WILL VOID ANY WARRANTY.

It is the responsibility of the purchaser to ensure that the incoming water supply is compliant with the listed specifications through adequate treatment measures.

Line pressure: Drinking water inlet: 3/4" NPT*, line pressure: 22 to 87 psi; 1.5 to 6 Bar (29 psi; 2 Bar recommended)

Inflow water specifications

Free chlorine ≤ 0.5 ppm

Chloramine ≤ 0.1 ppm

pH 7 - 8.5

Electrical conductivity ≤ 1000 µS/cm

Total hardness ≤ 30° dH

Chlorides ≤ 120 ppm

Steam circuit: inflow water specifications

Total hardness ≤ 8 °dH

Chlorides ≤ 25 ppm

To avoid the formation of limescale the incoming water must have total hardness ≤ 8°dH.

*This value refers to daily steam cooking of 1-2 hours. In any case, if with a total hardness ≤ 8°dH there is still production of limescale, it is mandatory to treat the water in order to avoid limescale production. Unox recommends water treatment systems based on ion exchange resins. Water treatment systems based on polyphosphate are not allowed.

Installation requirements

Installations must comply with all local electrical systems, particularly as for minimum wire gauge required for field connection, hydraulic and ventilation supply. Exhaust and fume analysis must be performed in case of gas ovens.

Register to DDC Service to access data and product specifications.
www.ddc.unox.com



XEVC-1011-E1RM

Project _____

Item _____

Quantity _____

Date _____

Model
CHEFTOP MIND.Maps™ ONE COUNTERTOP

Energy efficiency 42.6 kWh/day - 0 kg CO₂/day*

*More details on the last page.

Combi oven	Electric
10 trays GN 1/1	Hinge on the left side
9.5" Touch control panel	
Voltage: 380-415V 3N~ / 220-240V 3~	



Description

Technologically advanced combi oven able to handle different cooking processes (dehydrating, steaming, low temperature cooking, sous vide cooking, roasting, grilling, pan frying, regeneration regeneration and plate regeneration) and baking process (fresh and frozen bakery and pastry). Thanks to Unox Intensive Cooking technology that guarantees perfect results for each process.

Standard cooking features

Programs

- 1000+ Programs
- **MIND.Maps™**: draw the cooking processes directly on the display

Manual cooking

- **Temperature**: 30 °C – 260 °C
- Up to 9 cooking steps
- **CLIMA.Control**: humidity or dry air set by 10%
- Delta T cooking with core probe

Advanced and automatic cooking features

Unox Intensive Cooking

- **DRY.Maxi™**: rapidly extracts the humidity from the cooking chamber
- **STEAM.Maxi™**: produces saturated steam
- **AIR.Maxi™**: manage fans auto-reverse and pulse function
- **CLIMALUX™**: total control of the humidity in the cooking chamber





XEVC-1011-E1RM

Key features

- **ROTOR.Klean™**: automatic washing system
- Cooking chamber in high-resistance AISI 304 stainless steel with rounded edges
- Double glass
- Cooking chamber lighting through LED lights embedded in the door
- Tray supports with anti-tip system
- Drip collection system integrated in the door which works even when the door is open
- 4-speed fan system and high-performance heating elements
- Integrated DET&Rinse™ detergent container
- **Wi-Fi / USB data**: download/upload HACCP data
- **Wi-Fi / USB data**: download/upload programs

App and web services

- **Data Driven Cooking app & webapp**: check and monitor in real-time the operating conditions of your ovens, create and share new recipes. Artificial intelligence transforms consumption data into useful information and allows you to increase daily profits
- **Top Training app**: download the Unox Top.Training app and learn step by step all the secrets of your new oven's control panel

Accessories

- **Ventless hood**: steam condensing hood
- **Ventless hood with activated carbon filter**: steam condensing hood with activated carbon filter
- **SLOWTOP**: ideal solution for butchers and deli shops, that combines intense cooking processes with gentle ones, such as holding and night-time cooking
- **Neutral cabinet**: recommended solution to optimize your kitchen layout and always have everything in the right place
- **Stand**: the multifunctional support ideal for storing trays safely and placing your oven at the perfect height to work
- **QUICK.Load** and trolley system
- **Cooking Essentials**: special trays
- **DET&Rinse™ ECO**: eco formula for daily cleaning and the utmost respect for the environment. Ideal for mild level of dirt.
- **DET&Rinse™ ULTRAPLUS**: cleaning and rinse agents to combine maximum cleanliness with minimum consumption and long life for your oven
- **PURE / PURE.XL**: resin-based filtering system that eliminates from the water all substances that contribute to the formation of limescale inside the oven cooking chamber
- **PURE-RO**: Reverse osmosis system that eliminates Chlorides and limescale from water
- **Wi-Fi / Ethernet**: Connection board to keep the oven connected to Unox cloud, mandatory to extend the warranty

XEVC-1011-E1RM

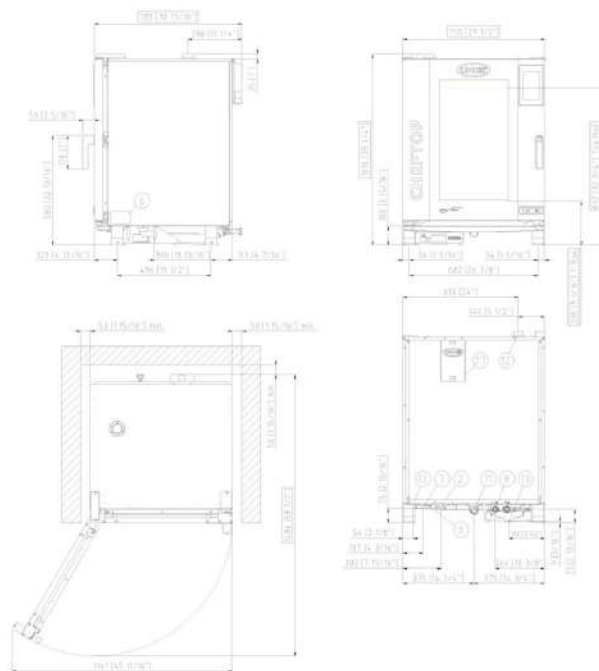

Dimensions and weight

Width	750 mm
Depth	783 mm
Height	1010 mm
Net weight	92 kg
Tray pitch	67 mm

Connection positions

2	Terminal board power supply
3	Unipotential terminal
6	Technical data plate
7	Safety thermostat
8	3/4" female NPT water inlet
10	Rotor.KLEAN™ inlet

11	Chamber drain pipe
12	Hot fumes exhaust chimney
13	Accessories connection
27	Cooling air outlet



XEVC-1011-E1RM

Electrical power supply

STANDARD

Voltage	380-415 V
Phase	~3PH+N+PE
Frequency	50 / 60 Hz
Total power	18,5 kW
Max Amp draw	26 A
Required breaker size	32 A
Power cable requirements*	5G x 4 mm ²
Plug	NOT INCLUDED

OPTION A

Voltage	220-240 V**
Phase	~3PH+PE
Frequency	50 / 60 Hz
Total power	18,5 kW
Max Amp draw	47.5 A
Required breaker size	50 A
Power cable requirements*	4G x 10 mm ²
Plug	NOT INCLUDED

**Electric connection kit

Item	XUC128
Voltage	220-240 V
Phase	~3PH+PE

*Recommended size - observe local ordinance.

Energy efficiency

Consumption

CO₂ emission

**The estimate includes only direct emissions produced by the oven. Indirect emissions can be reduced to zero by choosing to purchase energy from renewable sources.

Estimate based on daily use of the oven (300 days/year):

6 light loads of roast chickens (loaded at 20%), 1 full load of roast potatoes, 3 full loads cooking with steam 2 hours in an empty oven at 180 °C.

Estimated assuming the following weekly washing programs (42 weeks/year):

1 long wash, 1 medium wash.

Water Supply

USING A WATER SUPPLY THAT DOES NOT MEET UNOX'S MINIMUM WATER QUALITY STANDARDS WILL VOID ANY WARRANTY.

It is the responsibility of the purchaser to ensure that the incoming water supply is compliant with the listed specifications through adequate treatment measures.

Line pressure: Drinking water inlet: 3/4" NPT*, line pressure: 22 to 87 psi; 1.5 to 6 Bar (29 psi; 2 Bar recommended)

Inflow water specifications

Free chlorine ≤ 0.5 ppm

Chloramine ≤ 0.1 ppm

pH 7 - 8.5

Electrical conductivity ≤ 1000 µS/cm

Total hardness ≤ 30° dH

Chlorides ≤ 120 ppm

Steam circuit: inflow water specifications

Total hardness ≤ 8 °dH

Chlorides ≤ 25 ppm

To avoid the formation of limescale the incoming water must have total hardness ≤ 8°dH.

*This value refers to daily steam cooking of 1-2 hours. In any case, if with a total hardness ≤ 8°dH there is still production of limescale, it is mandatory to treat the water in order to avoid limescale production. Unox recommends water treatment systems based on ion exchange resins. Water treatment systems based on polyphosphate are not allowed.

Installation requirements

Installations must comply with all local electrical systems, particularly as for minimum wire gauge required for field connection, hydraulic and ventilation supply. Exhaust and fume analysis must be performed in case of gas ovens.

Register to DDC Service to access data and product specifications.
www.ddc.unox.com